

NINZ

FIREDOORS

General brochure



PRESENTATION - THE RELIABILITY OF EXPERIENCE

Ninz S.p.A. is Italy's leading producer of fire doors with a 70% market share. Consolidated experience in the sector, familiarity with standards and optimal quality-price ratios are the company's most distinguishing features. Over the years it has broadened its offer to include multipurpose metal doors and a wide range of accessories. In addition to Italy, Ninz S.p.A. also markets its products in more than 60 countries each year.

Production takes place in two different facilities - Bolzano and Ala (TN), where the departments for research and development, sales and logistics are also located. In Ala a third facility is currently under construction designed to further enhance production capacity.

From its beginnings as a small family-owned metal works company in 1953, over the years the company has evolved to become a major industrial player with 250 employees. The main impetus for growth came from its owner, Karl Ninz, who first introduced the production of fire doors in 1976.



DESIGN AND RESEARCH - EYES ON THE FUTURE

Continuous product improvements are managed by a team of expert engineers and technicians, who combine scrupulous attention to fire regulations with the practical concerns of builders, installers and locksmiths. This research, for instance, has generated certified installation methods for mounting fire doors on different types of support structures, such as masonry, plasterboard and sub-frames.



Thanks to the in-depth study of foreign standards, Ninz S.p.A. has also succeeded in certifying its products in a number of foreign countries, including France, Slovenia, Russia, Romania...

The company NINZ S.p.A. offers already today fire rated doors with "additional performances" which satisfy requirements of acoustic and thermal performances, resistance to windload and water-tightness, as well as multifunctional external doors which are **CE** marked.

PRODUCTION - VERSATILITY AND DESIGN

The daily production capacity is 2000 doors, which are currently divided into the PROGET line (fire rated and multipurpose), the UNIVER line (fire rated and multipurpose) and REVER line (multipurpose). Products are made to order for even the smallest quantities, satisfying the most demanding customers thanks to the wide variety of colors, accessories and windows available.

Customization of the product reaches a pinnacle with the NDD technology (Ninz Digital Decor), a trademark, NINZ decorative painting which permits any theme (words, pictures, logos) to be reproduced on the door-leaf surface. As an expression of the NDD claim, fire doors are transformed into versatile design elements at the disposal of architects and designers. This project earned the company the prestigious "Design Security & Safety Award" in 2007.



MARKETING - A SERVICE-ORIENTED PERSPECTIVE

Thanks to their reliability and quality, Ninz fire doors are used throughout Italy and in many countries across the world in public buildings where safety is at a premium: schools, hospitals, convention centers, shopping malls, manufacturing sites, hotels, museums...

The distribution within Italy is capillary thanks to a dense network of retailers supported by over one hundred sales agents.

Punctual delivery - one of the company's strongest points - is guaranteed by the careful planning of the production and by the quality transport services, which are both organized in-house.

The service that Ninz S.p.A. offers its customers is completed by the internal technical-sales department, which assists agents and customers in the pre- and post-sales phases, and by the fitting department, which directly follows product installations at the customer's request.

For international distribution, Ninz S.p.A. draws on (depending on the country) agents, exclusive retailers and networks of retailers supported by a dedicated internal technical-sales department.

Daily shipment to France is possible thanks to the special wooden-crates packaging and the local logistics network that has been created. Due to its great success, this service will soon be extended to other European countries.

CRIBIS PRIME COMPANY CERTIFICATE

Ninz S.p.A. has been awarded the Cribis Prime Company certificate by Cribis Dun & Bradstreet, an organisation that operates globally in the field of business information and collects reports on over 200 million companies in over 230 countries.

This new recognition for the 2018 year of reliability confirms our ability to maintain our leadership position, already recognised since 2015 with the 'Rating Cribis D&B 1' certificate. We have been recognised for the quality and product level, as well as for the effective organisational, administrative and financial management of the company.

The "Prime Company" certificate attests the solidity of our company, the punctuality in payments and our reliability, which is based exclusively on its own strong financial position and the total absence of debt to credit institutions.

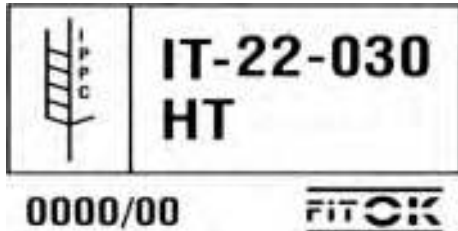

FITOK VOLUNTARY PHYTOSANITARY LABEL

One of Ninz S.p.A.'s key strengths has always been the punctual delivery of its products, which is made possible by the company's in-house packaging expertise. This packaging offers maximum protection against impacts during transport and perfect storage at the customer's premises before installation.

Considering this, Ninz S.p.A. has taken steps to preserve the possibility of sending its packaging to countries where phytosanitary treatment of wood is mandatory. It is important to note that wood, when used as a packaging material, represents a potential channel for the introduction and spread of harmful organisms. This is why it was necessary to implement certain phytosanitary measures in order to avoid any potential economic and environmental impacts on the world's forest heritage.

The Conlegno consortium has been recognised by the Ministry of Agriculture, Food and Forestry as the managing entity of the international product mark IPPC/FAO, which certifies phytosanitary procedures and treatments in compliance with ISPM Regulation N°15.



Ninz S.p.A. has been a member of the Conlegno consortium since 2008, obtaining the authorisation to manage and maintain the FI-TOK voluntary phytosanitary mark. Currently, Ninz purchases exclusively heat-treated wood semi-finished products from suppliers, free from parasites, which it uses to produce made-to-measure pallets and cages. Ninz S.p.A. has its own specially constructed automated plant for this purpose. As a result, Ninz is able to meet its customers' requests to mark pallets and cages with the FITOK phytosanitary mark for shipment to non-European countries that require compliance with ISPM Regulation N°15.

"state of the art in fire protection technology"





UNIVER NINZ Doors

FIRE RATED VERSION

FEATURES	8 - 11
SPECIFIC OPTIONAL ACCESSORIES	12 - 13
ADDITIONAL PERFORMANCES	14 - 22
DOOR CROSS SECTIONS - MEASUREMENTS	23
INSTALLATION METHODS	24
ORDER MEASUREMENTS	25- 26
OPENING MEASUREMENTS - OVERALL DIMENSIONS	27

WHAT MAKES THEM SPECIAL?

“Quality first”

- Fully galvanized door, including the “hidden” parts
- Made of “Sendzimir” processed hot-galvanized sheet metal
- Corrosion protection also provided along cut edges of the metal sheets
- Painted with epoxy-polyester thermoset powders in a 180 degrees (Celsius) oven
- Substantial paint layer (70 microns plus)
- Optimal corrosion resistance demonstrated by 500 hour salt-fog test
- Unaffected by severe climate changes, demonstrated by 2000 hours with +60° to -10° cycles at 75% humidity
- Finishing with high-quality aesthetics
- Orange skin anti-scratch structured paint
- Customizable with wide selection of RAL colors

“Practicality of use”

- Door reversibility
- Indication of door opening direction not necessary
- Reduction of stock for retailers
- Simplifies choices for end-customers
- Multiple installation methods for each door
- Type approvals for anchors for mortar fixing or expansion screws

“Conformity to standards”

- In-house Ninz R&D with specialized testing equipment
- Fire testing in accordance with UNI 9723 and EN 1634-1
- Mechanical testing for the CE marking of accessories
- CE-marked door accessories studied and sized to meet standard European requirements
- Careful selection of materials and manufacturing methods
- Strict product testing for conformity to declared technical standards
- Absolute functional certainty over time
- Doors “type approved” in compliance with M.D. 21 June 2004
- Products delivered with the documentation required by current regulations

“Manufacturing technology”

- Manufacturing in modern and functional facilities which employ the latest technologies to maintain high quality levels and product uniformity
- The entire production process - from raw materials to painted and packaged products - takes place inside Ninz’s own facilities, ensuring a 360 degree door control

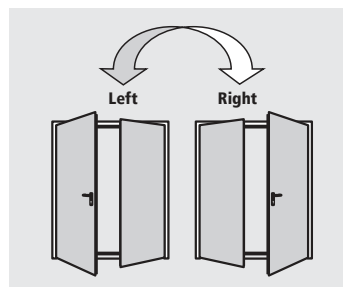
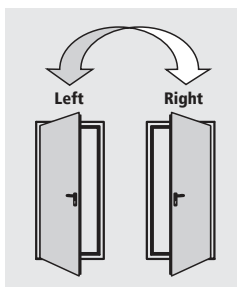

One-leaved doors available in the following classes:

E 60 EI₂ 60 EI₂ 90 REI 120 EI₂ 60 CE EI₂ 90 CE



Two-leaved doors available in the following classes:

EI₂ 60 EI₂ 90 REI 120 EI₂ 60 CE EI₂ 90 CE



STANDARD ELEMENTS

Door leaf

- Made of "Sendzimir" processed hot-galvanized sheet metal, press folded and electro welded
- Perimetral rebate on 4 sides
- Internally reinforced with hot-galvanized steel profiles
- Heat-insulated with treated mineral wool
- Internal stiffeners for overhead door closer and panic bar

Doorframe

- Made of "Sendzimir" processed hot-galvanized sheet metal
- Grooves for thermo expansive sealing and rebate sealing
- Suitable for anchors for mortar fixing or expansion screws
- Detachable rebate for application on finished flooring
- Removable threshold for thresholdless installation
- Strike plates in black plastic for lock bolt and safety bolts
- Assembled doorframes for one-leaved doors
- Assembly required for two-leaved doorframes

Thermo expansive sealing

- Mounted on vertical doorframe profiles and central vertical profiles on two-leaved doors
- For on-site mounting on the doorframe's upper cross-beam
- Mounted above and below the EI₂90 and REI 120 leaves



Hinges

- Nr. 2 three-wing hinges for each leaf
- of which one ball-bearing hinge with screws for vertical adjustment of the leaf, **CE** marked as per EN 1935, classified for up to 160 kg load, 200.000 cycles durability, suitable for fire door use
- and one hinge with self-closing spring

Safety bolts

- Nr. 2 safety bolts on hinge side leaf edge

Locking mechanism

- Reversible locking mechanism with bolt and central lock
- **CE** marked in conformity with EN 12209 standard
- Insert with patent key, Euro profile cylinder ready

Handle

- Fire rated handle in black plastic with steel core
- Steel installation plate with cylinder hole
- Cover plate in black plastic
- Fastener screws and patent key insert



INCLUDED ACCESSORIES

Closing regulator

- Two-leaved doors include an RC/STD closing regulator to ensure the correct closing sequence of the leaves
- CE marking in conformity with EN 1158 standard

Locking mechanism for inactive leaf

- "Flush-bolt" automatic locking of the inactive leaf
- Lever control for unlocking

Upper coupling system for the inactive leaf

- Inactive leaf lock activated device which inserts rod into the upper strike box
- Upper strike box in black plastic with steel roller

Lower coupling system for the inactive leaf

- Vertical rod with steel point which inserts into lower strike box
- Floor catch (floor-mounted floor catch) made of self-extinguishing black plastic, for doors without threshold
- Floor catch in black plastic with a steel roller, for doors with threshold

Identification plate

- Metal tag with door identification data, in accordance with current regulations



Standard paint - group 01: RAL 9010



Finishing

- Standard painted with epoxy-polyester thermoset powders in a 180 degrees oven, orange skin, anti-scratch finishing
- Standard paint RAL 9010

Standard packaging

- Single door wrapped into stretchable polyethylene (PE) film
- Assembled doorframes for one-leaved doors
- Assembly required for doorframes for two-leaved doors
- Palletized on wooden pallets

Door weight

class	kg/m ² of wall opening	
	1 leaf	2 leaves
E 60	23	-
EI,60	36	35
EI,90, REI 120	43	41

NOTE

If the door ever needs to be repainted, follow the precise instructions on the "Painting" section.

OPTIONAL ACCESSORIES

A wide variety of accessories and surface finishes are available on request for maximum value enhancement of Univer doors to your own specific needs.

The proper accessories can help resolve:

Safety-related needs

- Doors for panic exits (see panic bars)
- Doors for emergency exits (see emergency exit handles)
- Open doors which must be closed in case of fire (see leaf holding systems)

Installation and utilization needs

- Frame extensions
- Drip steel-profile
- Special fastener screws
- Kick and protection plates in stainless steel
- Windows
- Roofing

Access-related control issues

- Electrically-activated lock mechanisms
- Electric handle mechanisms
- Magnetic blocking mechanisms

Performance enhancing

- Sealing
- Cylinders
- Door closers
- Special closing regulators
- Special handles



NOTE

Details on the optional accessories may be found in the following chapters of this brochure:

- Painting
- Accessories for metal doors
- Emergency handles and panic bars

Right-opening doors are the default selection if opening direction is not specified.

Customized finishing

- Select finishing from a wide variety of RAL colours
- NDD – Ninz Digital Decor, graphic images applied with special ink jets and protected by a transparent topcoat. Infinite varieties of customizable decorations in harmony with specific door settings
- Stainless steel handles
- Colored handles

Packaging for maximum protection

Sturdy wooden crates protect all doors and related accessories:

- For NDD decorated doors
- On construction sites
- During shipping abroad
- For special transport

The following optional accessories make Univer doors irreversible, requiring the indication of the door opening direction when the order is placed:

- SLASH panic bar
- Panic bar for inactive leaves
- Windows
- MAC lock
- ELM/cisa and ELM/mt electric handle
- Special locks (Stel 15)
- NDD - Ninz Digital Decor

WINDOW WITH FIRE RATED GLASS

Upon request all one- and two-leaved fire doors, excluding those E 60, EI₂30 and EI₂90 rated, may be equipped with round or rectangular windows with fire rated stratified glass and respective window frames fixed with screws. The window frame carters are included for round window and available as an optional accessory for the rectangular one.

Limits prescribed by standard

According to standards UNI 9723 and EN 1634-1, windows may be smaller but not larger than the test sample size, and the reverse holds true for the border strip around the window which may be wider but not thinner. The following limits correspond with these restrictions.

Borders, window position

"Border measurement" refers to the distance from the edge of the window to the wall opening of the door.

Elevation for round windows

window size	FM H	position
Ø 300	minimum 2050	Y=1600
Ø 300	less than 2050	Y=FM H - 450
Ø 400	minimum 2150	Y=1600
Ø 400	from 2050 to 2149	Y=1550
Ø 400	less than 2050	Y=FM H - 500

Elevation for rectangular windows

window dimensions L x H	FM H	position
250/300 x 400	minimum 2150	Z=1450
250/300 x 400	from 2050 to 2149	Z=1350
250/300 x 400	less than 2050	Z=FM H - 700

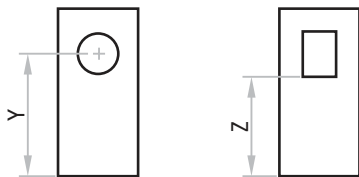

NOTE

The positions indicated above are those standard. Different positions may be considered as long as they respect the minimum "a" and "b" border strips. The window itself may not be supplied separately except for replacements. It is always advisable for doors with windows to be equipped with door closers for controlled closing.



NOTE

For the rectangular windows the frame carters are an optional accessory

Round window cross section

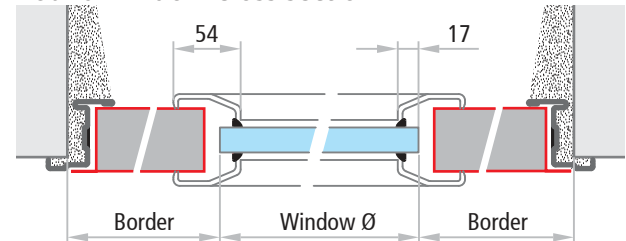

Rectangular window cross section

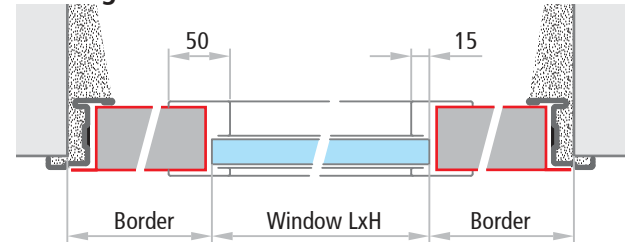

ATTENTION

In case of external installation use windows designed for this purpose. For special instructions and recommendations for glazed fire-rated products, see the "Notices" section on the last page of the present brochure.

Specific optional accessories

UNIVER Fire doors



UNIVER
fire door

Window dimensions	min. border EI ₂		min. border RE, REI		dimensions FM L min.
	a	b	a	b	
	Ø 300	220	220	300	740
	Ø 400	300	300	300	840
	Ø 300	220	220	300	L1 740 + L2 min.
	Ø 400	300	300	300	L1 840 + L2 min.
	Ø 300	220	220	300	L1 740 + L2 740
	Ø 400	300	300	300	L1 840 + L2 840

Window dimensions	min. border EI ₂		min. border RE, REI		dimensions FM L min.	
	a	b	a	b		
	250 x 400	250	300	300	EI ₂ =750	RE, REI=850
	300 x 400	300	300	300	EI ₂ =800	RE, REI=900
	250 x 400	300	300	300	L1 850 + L2 min.	
	300 x 400	300	300	300	L1 900 + L2 min.	
	250 x 400	300	300	300	L1 850 + L2 850	
	300 x 400	300	300	300	L1 900 + L2 900	

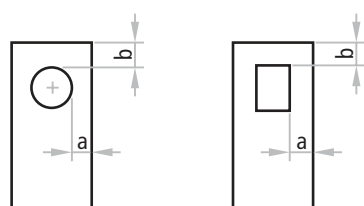

NOTE

Round and rectangular windows not possible for one-leaved REI doors with FM L (wall opening) above 1167mm and FM H above 2150mm.

Round windows are not allowed for CE fire doors

FRAME EXTENSIONS FOR UNIVER DOORS

IM 12

Frame extensions to be mounted in addition to the Univer frame acting as a wall cladding. Made of "Sendzimir" processed hot-galvanized sheet metal and painted the same color as the doorframe with epoxy-polyester powders. Profile on three sides, upper corners with 45 degree joint, fixing with screws and plugs (screws and plugs not included).

IM 12: for installation on 80mm (min.) wall thickness

IM 14

Telescopic frame extensions to be screwed to the Univer doorframe acting as a wall cladding. Consists of two overlapping profiles with a 25mm adjustable range. Made of "Sendzimir" processed hot-galvanized sheet metal painted the same color as the doorframe with epoxy-polyester powders. Profile on three sides, upper corners with 90 degree joint. Complete with fastener screws. To mount the frame extension, fixing holes need to be drilled into doorframe on site. Combine with sealing to conceal the screw heads.

IM 14: for installation on 135mm (min.) wall thickness

REBATE SEALING CR

CR sealing (for EI₂ doors) and sealing (for REI doors) in black extruded profile to cut and to be pressed into the dedicated groove in the perimetral frame. Sealing in black extruded profile self-adhesive to cut for application to the central joint of two-leaved doors.

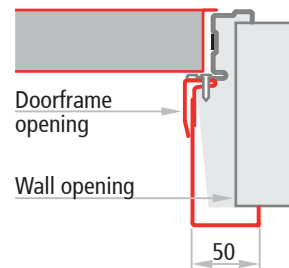
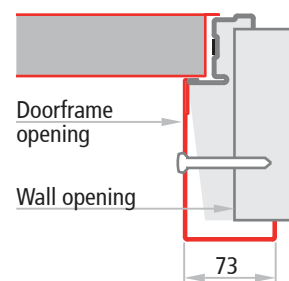

Additional performances

UNIVER Fire doors



UNIVER
fire door



INTERNAL PEDESTRIAN DOORS

Test report No. CPR/35/05/2019 (E 60)

Test report No. CPR/35/04/2019 (EI₂60)

Test report No. CPR/35/07/2019 (REI 120/EI₂90)

Pedestrian interior doors are not yet subject to marking as the relevant standard EN 14351-2 has not yet entered into force. The performances contained in the standard can however be a reference for classifying the door for indoor, such as:

- air permeability according to EN 1026:2001
- thermal transmittance according to EN ISO 10077-1:2018 e EN ISO 10077-2:2018

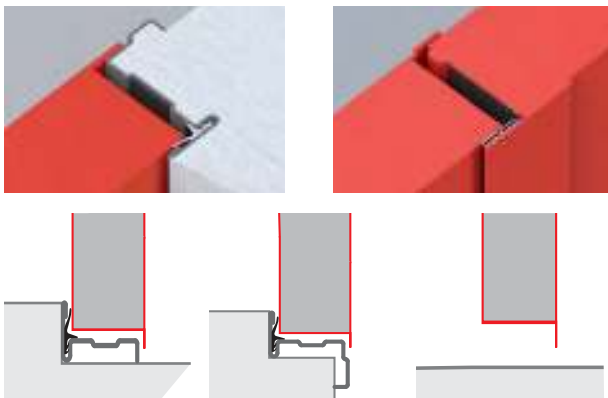

All performance values indicated in the table are valid only in presence of the following accessories or enhancements:

- Combo Thermo/CB (with lower threshold):
 - frame on all 4 sides
 - if the door is installed on an escape route, it is necessary to fill the difference in height on the push side between the floor and the lower threshold with cement mortar
 - isolation of the door frame with the filling of cement mortar
 - installation of rubber seals along the entire perimeter of the door frame including the central rebate for double leaved doors
 - sealing of the perimeter of the frame (push side) with neutral silicone
- Combo Thermo/SB (without lower threshold):
 - isolation of the door frame with the filling of cement mortar
 - installation of rubber seals along the 3 sides of the frame including the central rebate for two-leaved doors
 - sealing of the perimeter of the frame (push side) with neutral silicone

ATTENTION

For the dimensional limits, minimum border measurements or production possibilities please refer to the specific pages of this brochure.

The values for the thermal transmittance W/m^2K shown in the table on the next page are given by the calculation according to the norm EN ISO 10077-1 done on samples of the dimensions 1,23x2,18 for areas $\leq 3,6m^2$ and on samples of the dimensions 2,00x2,18 for areas $> 3,6m^2$.

Consiglio Nazionale delle Ricerche
Istituto per la BioEconomia

CNR IBE - Via F. Biagi n. 75, San Michele all'Adige - Trento T. 0461 660111 Fax 0461 650045

CNR - IBE		LABORATORIO SERRAMENTI E FACCIATE CONTINUE	
U 0000804	13/02/2020	RAPPORTO DI PROVA N° CPR/35/06/2019	
		San Michele all'Adige, 07/02/2020	
COMMITTENTE: NINZ S.p.a. Corso Trento, 2/A - 38061 Ala (TN)			
COSTRUTTORE: NINZ S.p.a. Corso Trento, 2/A - 38061 Ala (TN)			
OGGETTO: PORTA			
MODELLO: UNIVER REI 120 / EI ₂ 90			
MATERIALE: profilato metallico, coibente			
DIMENSIONI: Spessore anta (mm) 60			
PROVE ESEGUITE SOTTO NOTIFICA (NB 2127): <input type="checkbox"/> CALCOLO DELLA TRASMITTANZA TERMICA SECONDO NORME UNI EN ISO 10077-2:2018 e UNI EN ISO 10077-1:2018 Note:.....			
DATA ACCETTAZIONE PREVENTIVO: 23/12/2019 (prot.n. 0003210/2019) DATA INIZIO PROVE: 04/02/2020 DATA FINE PROVE: 06/02/2020			
IL PRESENTE RAPPORTO DI PROVA È COMPOSTO DA: n° 05 pagine di rapporto di prova n° 23 pagine di allegati tecnici			
MOD 00 00 13 - Format Rev.05		Rapporto di prova rilasciato sotto notifica ai sensi del Reg. (UE) n. 305/2011 (CPR)	
FIRENZE	BOLOGNA	CATANIA	ROMA
SASSARI	S.MICHELE ALL'ADIGE		

C.F. 8006430696 - P.IVA 02118311006



PEC: protocollo.ibe@pec.cnr.it

Additional performances

UNIVER Fire doors



UNIVER fire door

Univer Fire doors Test report CPR/35/07/2019 Test report CPR/35/05/2019 Test report CPR/35/04/2019 		DIMENSION FM L X H	Combo Thermo/CB with lower threshold and gasket on all 4 sides			Combo Thermo/SB without lower threshold CR and gasket on 3 sides		
			EI ₂ 60	E60	REI 120	EI ₂ 60	E60	REI 120
Without window 	UNI EN 1026:2001	≤ 3,6 m ²						
	Air permeability		Class 2	Class 2	Class 2	N.PD.	N.PD.	N.PD.
	UNI EN 10077-1-2:2018							
	Thermal transmittance		1,5 W/m ² K	1,6 W/m ² K	1,5 W/m ² K	1,5 W/m ² K	1,6 W/m ² K	1,5 W/m ² K

Additional performances

UNIVER Fire doors



UNIVER
fire door

INTERNAL PEDESTRIAN DOORS



SMOKE CONTROL

Test report IFT N° 16-000122-PR03

This is the ability of a door set to reduce or eliminate the passage of smoke from one side of the door to the other. Two levels of smoke performance are defined.

Smoke control Sa: when the maximum dispersion value measured at room temperature and at a pressure of 25 Pascal is not greater than 3 m³/h per metre through the gap between the door leaf and the door frame excluding eventual losses through the floor threshold.

Smoke control S200: when the maximum dispersion value, measured at room temperature and 200 C and up to a pressure of 50 Pascal, is not greater than 20 m³/h for a single door or 30 m³/h for a two-door door.

The smoke tightness is verified with a specific technical test in accordance with UNI EN 1634-3, while the classification is provided by UNI EN 13501-2 according to the following criteria:

Sa considers only the seal at room temperature

S200 considers the seal at room temperature and at 200 C

UNIVER doors are certified for smoke control according to EN 1634-3 and classified Sa/S200 according to EN 13501-2 . The price list lists the Combos which add these additional performances to the door.

ATTENTION

The smoke control performance is only valid in presence of the following accessories or enhancements:

- no fixed threshold
- filling of the slot between frame and wall with cement mortar
- installation of rubber seals along the entire perimeter of the door frame including the central rebate for double leaved doors
- presence of the automatic door sweep
- closing regulator RC/STD for the correct closure of double leaved doors



S200, C5 ENHANCED PERFORMANCES

Mandatory accessories

Enhanced performance	features	type	mandatory optional accessories	reference in brochure
S200	Smoke control Door	1 leaf	- rubber seal CR - Nr. 1 automatic door sweep	UNIVER fire door ACCESSORIES
		2 leaves	- rubber seal CR - Nr. 2 automatic door sweep	UNIVER fire door ACCESSORIES
C5	Durability: 200,000 cycles	1 leaf	- Nr. 1 door closer	ACCESSORIES
		2 leaves	- Nr. 2 door closers	ACCESSORIES

MECHANICAL STRENGTH PERFORMANCES

Test report according to norm EN 947, EN 948, EN 949, EN 950

Performance requirements and classifications

class	tested FM L X H dimensions	type	description of the performance	reached class	standard reference
EI ₂ 60	2000 (1000 + 1000) x 2125	2 leaves	resistance to vertical load	4	EN 1192:2002
			resistance to static torsion	4	EN 1192:2002
			resistance to soft and heavy body impact	4	EN 1192:2002
			resistance to hard body impact	3	EN 1192:2002

Additional performances

UNIVER Fire doors



UNIVER fire door

EXTERNAL PEDESTRIAN DOORS

Certificate CE 1404-CPR-3734 for EI₂60
 Certificate CE 1404-CPR-3735 for EI₂90
 EN 16034:2014 and EN 14351-1:2006+A2:2016



According to standards EN 16034 and EN 14351-1, an external door is defined as a door that separates the internal climate from the external environment of a building. For this application, doors must be CE marked in accordance with EN 16034:2014 and EN 14351-1:2006+A2:2016. Furthermore, if the door is installed along an escape route and equipped with a panic or emergency exit device, it is also subject to the assessment and verification of constancy of performance under "System 1". This requires the manufacturer to hold a Certificate of Constancy of Performance issued by a Notified Body — for NINZ S.p.A., those are certificates 1404 - CPR - 3734 and 1404 - CPR - 3735.

Univer fire doors for external use must be ordered with the specific CE Combo Est options available in the Univer fire door price list, selected based on the essential requirements indicated in the tables on the following pages, and considering those that are mandatory according to the applicable national regulations. This ensures that each door is provided with the required CE marking and the documentation specified by the current legislation.

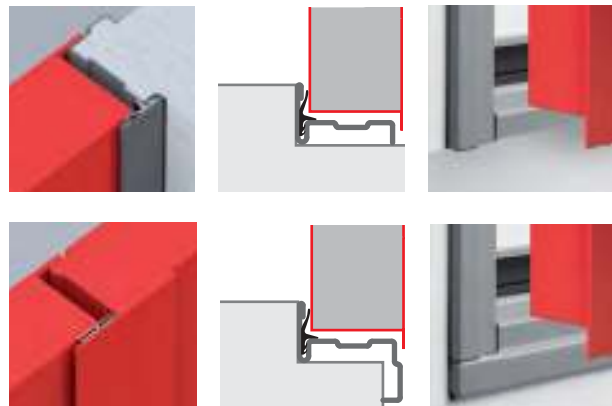

ATTENTION

For dimensional limits, minimum edge requirements and production options, please refer to the specific pages of this catalogue. The thermal transmittance values (W/m²K) shown in the tables on the following pages are calculated in accordance with EN ISO 10077-1, applied to samples measuring 1.23 x 2.18 m for areas ≤ 3.6 m² and to samples measuring 2.00 x 2.18 m for areas > 3.6 m². All performance values listed in the table are valid only if the door is installed with the following accessories and measures:

- presence of a bottom rebate threshold
- in case of installation along an escape route, the floor on the push side must be raised to fully level the gap between the floor and the bottom threshold
- frame insulation by filling with polyurethane foam or cement-based mortar
- application of sealing gaskets along the entire perimeter of the frame and on the central mullion in double-leaf doors
- sealing of the frame's perimeter edge (on the push side) with neutral silicone
- for doors with vision panels: installation of external fire-resistant glazing sized 300x400 mm

NOTES

For information regarding outdoor installation, please refer to the "Warnings" section on the last page of this catalogue.



Certificate of constancy of performance

1404 – CPR – 3734

In compliance with Regulation (EU) No 305/2011 of the European Parliament and of the Council of 9 March 2011 (the Construction Products Regulation or CPR), this certificate applies to the construction product

Single and double leaf fire door UNIVER EI 60
 (doors that fall within the scope of standard EN 14351-1:2006+A2:2016)

placed on the market under the name or trade mark of
NINZ S.p.A.,
 Corso Trento 2, 38061 Ala (TN), Italy

and produced in the manufacturing plant
NINZ S.p.A.,
 Corso Trento 2, 38061 Ala (TN), Italy.

This certificate attests that all provisions concerning the assessment and verification of constancy of performance described in Annex ZA of the standards

EN 16034:2014 and EN 14351-1:2006+A2:2016

under system 1 for the performance set out in this certificate are applied and that the factory production control conducted by the manufacturer is assessed to ensure the

constancy of performance of the construction product.

This certificate was first issued on 4. 6. 2024 and will remain valid until 4. 6. 2029 as long as neither the harmonised standards, the construction products, the AVCP method nor the manufacturing conditions in the plant are modified significantly, unless suspended or withdrawn by the notified product certification body.

Detailed information about the scope of the product is given in the annex to this certificate.

Ljubljana, 4. 6. 2024



Authorised signatory of the Certification body:
 mag. Egon Mioš, univ.dipi.inž.grad.

Additional performances

UNIVER Fire doors



UNIVER
fire door



UNIVER Fire Door EI ₂ 60  Certificate CE: 1404-CPR-3734		Angular Frame	Combo with bottom rebate, CR compression seal on all four sides and door closer for C5 version		Combo with CR compression seal on 3 sides, drop-down seal and door closer for C5 version	
			CE	CE C5	CE S200/GS CE S 200/GSV	CE S200/GS C5 CE S200/GSV C5
Without window 	EN 16034:2014					
	Fire resistance	✓	EI ₂ 60	EI ₂ 60	EI ₂ 60	EI ₂ 60
	Smoke control	✓	N.P.D.	N.P.D.	Sa / S200	Sa / S200
	Ability to release / lock	✓	N.P.D.	N.P.D.	N.P.D.	N.P.D.
	Self-closing	✓	C	C	C	C
	Durability of release mechanism	✓	N.P.D.	N.P.D.	N.P.D.	N.P.D.
	Durability of self-closing					
	- against degradation	✓	0	5	0	5
	- against corrosion	✓	N.P.D.	N.P.D.	N.P.D.	N.P.D.
	EN 14351-1:2006+A2:2016					
	Air permeability	✓	2	2	2	2
	Water tightness	✓	2A	2A	N.P.D.	N.P.D.
	Wind load resistance					
	- Door with FM ≤ 900x2150	✓	C2	C2	N.P.D.	N.P.D.
	- Door with FM > 900x2150	✓	N.P.D.	N.P.D.	N.P.D.	N.P.D.
	Impact resistance	✓	N.P.D.	N.P.D.	N.P.D.	N.P.D.
	Load-bearing capacity of safety devices	✓	Exceeds	Exceeds	Exceeds	Exceeds
	Acoustic performance	✓	N.P.D.	N.P.D.	N.P.D.	N.P.D.
	Thermal transmittance	✓	1,49 W/m ² K	1,49 W/m ² K	N.P.D.	N.P.D.
	Ability to release / open	✓	N.P.D.	N.P.D.	N.P.D.	N.P.D.
With window 300x400 	EN 16034:2014					
	Fire resistance	✓	EI ₂ 60	EI ₂ 60	EI ₂ 60	EI ₂ 60
	Smoke control	✓	N.P.D.	N.P.D.	Sa / S200	Sa / S200
	Ability to release / lock	✓	N.P.D.	N.P.D.	N.P.D.	N.P.D.
	Self-closing	✓	C	C	C	C
	Durability of release mechanism	✓	N.P.D.	N.P.D.	N.P.D.	N.P.D.
	Durability of self-closing					
	- against degradation	✓	0	5	0	5
	- against corrosion	✓	N.P.D.	N.P.D.	N.P.D.	N.P.D.
	EN 14351-1:2006+A2:2016					
	Air permeability	✓	2	2	2	2
	Water tightness	✓	2A	2A	N.P.D.	N.P.D.
	Wind load resistance					
	- Door with FM ≤ 900x2150	✓	C2	C2	N.P.D.	N.P.D.
	- Door with FM > 900x2150	✓	N.P.D.	N.P.D.	N.P.D.	N.P.D.
	Impact resistance	✓	N.P.D.	N.P.D.	N.P.D.	N.P.D.
	Load-bearing capacity of safety devices	✓	Exceeds	Exceeds	Exceeds	Exceeds
	Acoustic performance	✓	N.P.D.	N.P.D.	N.P.D.	N.P.D.
	Thermal transmittance	✓	2,01 W/m ² K	2,01 W/m ² K	N.P.D.	N.P.D.
	Ability to release / open	✓	N.P.D.	N.P.D.	N.P.D.	N.P.D.

Additional performances

UNIVER Fire doors



UNIVER
fire door

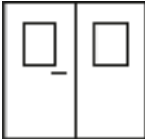
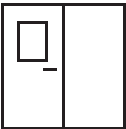

UNIVER Fire Door EI ₂ 60  Certificate CE: 1404-CPR-3734		Angular Frame	Combo with bottom rebate, CR compression seal on all four sides and door closer for C5 version		Combo with CR compression seal on 3 sides, drop-down seal and door closer for C5 version	
			CE	CE C5	CE S200/GS CE S 200/GSV	CE S200/GS C5 CE S200/GSV C5
Without win- dow 	EN 16034:2014					
	Fire resistance	✓	EI ₂ 60	EI ₂ 60	EI ₂ 60	EI ₂ 60
	Smoke control	✓	N.P.D.	N.P.D.	Sa / S200	Sa / S200
	Ability to release / lock	✓	N.P.D.	N.P.D.	N.P.D.	N.P.D.
	Self-closing	✓	C	C	C	C
	Durability of release mechanism	✓	N.P.D.	N.P.D.	N.P.D.	N.P.D.
	Durability of self-closing					
	- against degradation	✓	0	5	0	5
	- against corrosion	✓	N.P.D.	N.P.D.	N.P.D.	N.P.D.
	EN 14351-1:2006+A2:2016					
	Air permeability	✓	3	3	3	3
	Water tightness	✓	3A - 9B	3A - 9B	N.P.D.	N.P.D.
	Wind load resistance					
	- Door with FM ≤ 2000x2150	✓	C2	C2	N.P.D.	N.P.D.
	- Door with FM > 2000x2150	✓	N.P.D.	N.P.D.	N.P.D.	N.P.D.
	Impact resistance	✓	N.P.D.	N.P.D.	N.P.D.	N.P.D.
	Load-bearing capacity of safety devices	✓	Exceeds	Exceeds	Exceeds	Exceeds
	Acoustic performance	✓	N.P.D.	N.P.D.	N.P.D.	N.P.D.
	Thermal transmittance for FM ≤ 3,6 m ²	✓	1,88 W/m ² K	1,88 W/m ² K	N.P.D.	N.P.D.
	Thermal transmittance for FM > 3,6 m ²	✓	1,52 W/m ² K	1,52 W/m ² K	N.P.D.	N.P.D.
Ability to release / open	✓	N.P.D.	N.P.D.	N.P.D.	N.P.D.	
With window 300x400  	EN 16034:2014					
	Fire resistance	✓	EI ₂ 60	EI ₂ 60	EI ₂ 60	EI ₂ 60
	Smoke control	✓	N.P.D.	N.P.D.	Sa / S200	Sa / S200
	Ability to release / lock	✓	N.P.D.	N.P.D.	N.P.D.	N.P.D.
	Self-closing	✓	C	C	C	C
	Durability of release mechanism	✓	N.P.D.	N.P.D.	N.P.D.	N.P.D.
	Durability of self-closing					
	- against degradation	✓	0	5	0	5
	- against corrosion	✓	N.P.D.	N.P.D.	N.P.D.	N.P.D.
	EN 14351-1:2006+A2:2016					
	Air permeability	✓	3	3	3	3
	Water tightness	✓	3A - 9B	3A - 9B	N.P.D.	N.P.D.
	Wind load resistance					
	- Door with FM ≤ 2000x2150	✓	C2	C2	N.P.D.	N.P.D.
	- Door with FM > 2000x2150	✓	N.P.D.	N.P.D.	N.P.D.	N.P.D.
	Impact resistance	✓	N.P.D.	N.P.D.	N.P.D.	N.P.D.
	Load-bearing capacity of safety devices	✓	Exceeds	Exceeds	Exceeds	Exceeds
	Acoustic performance	✓	N.P.D.	N.P.D.	N.P.D.	N.P.D.
	Thermal transmittance for FM ≤ 3,6 m ²	✓	2,91 W/m ² K	2,91 W/m ² K	N.P.D.	N.P.D.
	Thermal transmittance for FM > 3,6 m ²	✓	2,15 W/m ² K	2,15 W/m ² K	N.P.D.	N.P.D.
Ability to release / open	✓	N.P.D.	N.P.D.	N.P.D.	N.P.D.	

Additional performances

UNIVER Fire doors



UNIVER
fire door



UNIVER Fire Door EI ₂ 90  Certificate CE: 1404-CPR-3735		ANguar Frame	Combo with bottom rebate, CR compression seal on all four sides and door closer for C5 version		Combo with CR compression seal on 3 sides, drop-down seal and door closer for C5 version	
			CE	CE C5	CE S200/GS CE S 200/GSV	CE S200/GS C5 CE S200/GSV C5
Without window 	EN 16034:2014					
	Fire resistance	✓	EI ₂ 90	EI ₂ 90	EI ₂ 90	EI ₂ 90
	Smoke control	✓	N.P.D.	N.P.D.	Sa / S200	Sa / S200
	Ability to release / lock	✓	N.P.D.	N.P.D.	N.P.D.	N.P.D.
	Self-closing	✓	C	C	C	C
	Durability of release mechanism	✓	N.P.D.	N.P.D.	N.P.D.	N.P.D.
	Durability of self-closing					
	- against degradation	✓	0	5	0	5
	- against corrosion	✓	N.P.D.	N.P.D.	N.P.D.	N.P.D.
	EN 14351-1:2006+A2:2016					
	Air permeability	✓	2	2	2	2
	Water tightness	✓	2A	2A	N.P.D.	N.P.D.
	Wind load resistance					
	- Door with FM ≤ 900x2150	✓	C2	C2	N.P.D.	N.P.D.
	- Door with FM > 900x2150	✓	N.P.D.	N.P.D.	N.P.D.	N.P.D.
	Impact resistance	✓	N.P.D.	N.P.D.	N.P.D.	N.P.D.
	Load-bearing capacity of safety devices	✓	Exceeds	Exceeds	Exceeds	Exceeds
	Acoustic performance	✓	N.P.D.	N.P.D.	N.P.D.	N.P.D.
	Thermal transmittance	✓	1,49 W/m ² K	1,49 W/m ² K	N.P.D.	N.P.D.
	Ability to release / open	✓	N.P.D.	N.P.D.	N.P.D.	N.P.D.

Additional performances

UNIVER Fire doors



UNIVER
fire door

UNIVER Fire Door EI ₂ 90  Certificate CE: 1404-CPR-3735		Angular Frame	Combo with bottom rebate, CR compression seal on all four sides and door closer for C5 version		Combo with CR compression seal on 3 sides, drop-down seal and door closer for C5 version	
			CE	CE C5	CE S200/GS CE S 200/GSV	CE S200/GS C5 CE S200/GSV C5
Without window 	EN 16034:2014					
	Fire resistance	✓	EI ₂ 90	EI ₂ 90	EI ₂ 90	EI ₂ 90
	Smoke control	✓	N.P.D.	N.P.D.	Sa / S200	Sa / S200
	Ability to release / lock	✓	N.P.D.	N.P.D.	N.P.D.	N.P.D.
	Self-closing	✓	C	C	C	C
	Durability of release mechanism	✓	N.P.D.	N.P.D.	N.P.D.	N.P.D.
	Durability of self-closing					
	- against degradation	✓	0	5	0	5
	- against corrosion	✓	N.P.D.	N.P.D.	N.P.D.	N.P.D.
	EN 14351-1:2006+A2:2016					
	Air permeability	✓	3	3	3	3
	Water tightness	✓	3A - 9B	3A - 9B	N.P.D.	N.P.D.
	Wind load resistance					
	- Door with FM ≤ 2000x2150	✓	C2	C2	N.P.D.	N.P.D.
	- Door with FM > 2000x2150	✓	N.P.D.	N.P.D.	N.P.D.	N.P.D.
	Impact resistance	✓	N.P.D.	N.P.D.	N.P.D.	N.P.D.
	Load-bearing capacity of safety devices	✓	Exceeds	Exceeds	Exceeds	Exceeds
	Acoustic performance	✓	N.P.D.	N.P.D.	N.P.D.	N.P.D.
	Thermal transmittance for FM ≤ 3,6 m ²	✓	1,88 W/m ² K	1,88 W/m ² K	N.P.D.	N.P.D.
	Thermal transmittance for FM > 3,6 m ²	✓	1,51 W/m ² K	1,51 W/m ² K	N.P.D.	N.P.D.
Ability to release / open	✓	N.P.D.	N.P.D.	N.P.D.	N.P.D.	

✓

Additional performances

UNIVER Fire doors

NINZ
FIREDOORS

UNIVER
fire door

Essential requirements*	EN 16034	EN 14351
Fire resistance	YES	NO
Smoke control	YES	NO
Self - closing	YES	NO
Durability of performance	YES	NO
Thermal insulation	NO	YES
Air permeability	NO	YES
Water tightness	NO	NO
Acoustic performance	NO	NO
Wind resistance	NO	NO
Load-bearing capacity of safety devices	NO	YES
Release/unlocking capability (mandatory for doors installed on escape routes)	NO	YES
Minimum clear passage height: 2000 mm	NO	YES

WARNING

For doors exposed to weather conditions and/or direct sunlight, the customer must take appropriate precautions to prevent long-term deterioration, in particular:

- Canopies or overhangs
- Outdoor paint with UV protection
- Use of light RAL colours to avoid overheating of metal sheets

* Required under binding national provisions

Door cross sections - Measurements

UNIVER Fire doors



UNIVER fire door

One-leaved doors
Horizontal cross section

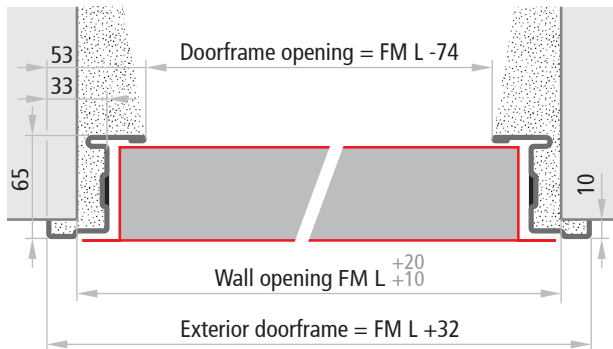

Doors without lower threshold
Vertical cross section

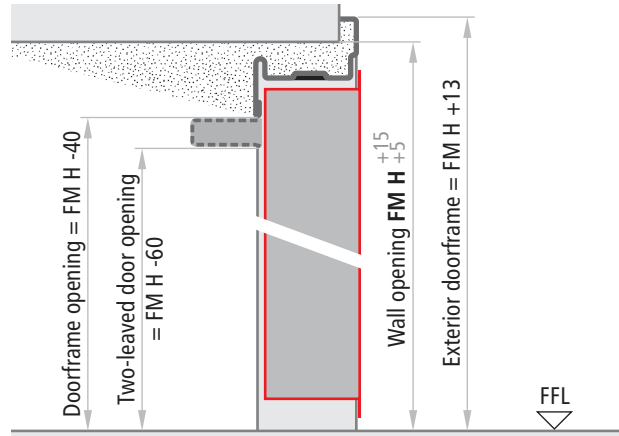

Doors with internal and external lower thresholds
Vertical cross section

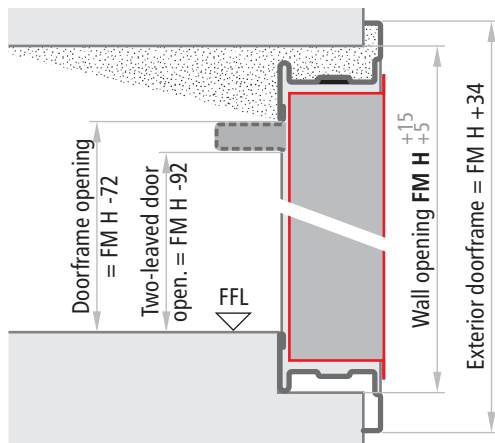

Doors with internal lower threshold
Vertical cross section

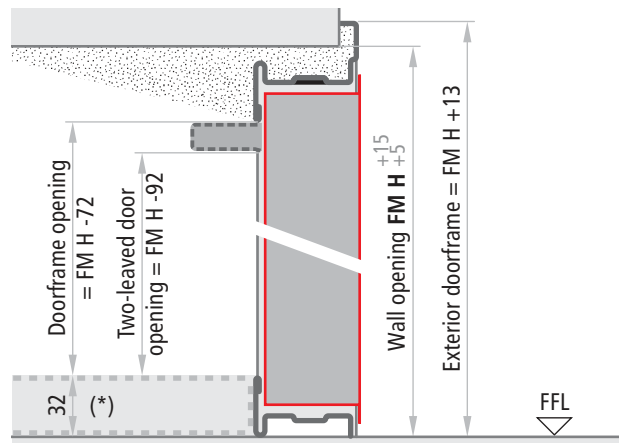

Two-leaved doors
Horizontal section

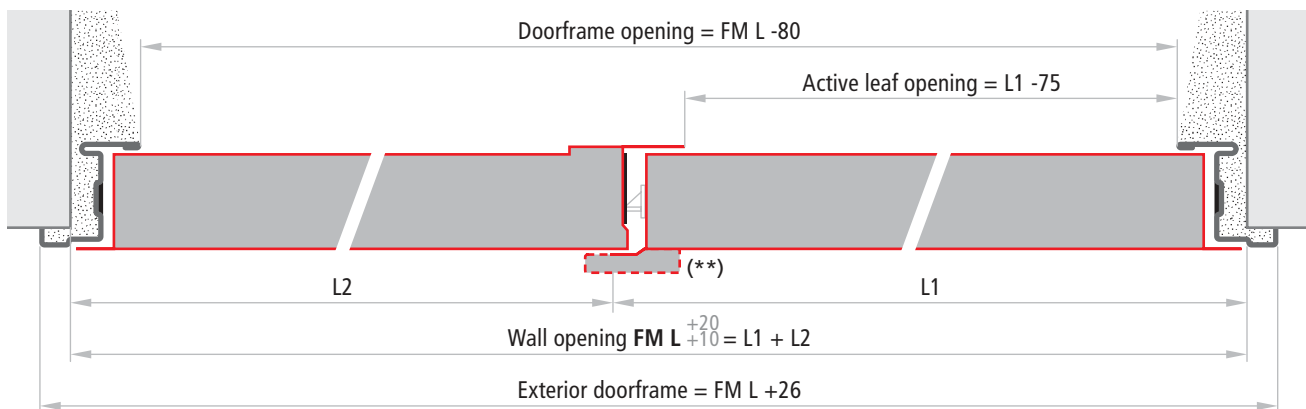

Leaves thickness

Fire doors	60 mm
------------	-------

NOTE

The tolerances FM L +20, FM L +10, FM H +15, FM H +5 of the indicated measurements make it easier to fill the gap between the wall and the doorframe with cement mortar.

(*) Shimming to be done, mandatory in case of installation onto emergency exit routes.

(**) Only for EI₂90 fire rated doors

Installation methods

UNIVER Fire doors



UNIVER
fire door

INSTALLATION WITH ANCHORS FOR MORTAR FIXING



For mortar fixing, appropriate cuts will need to be created in the walls (section 80 x 200 mm). The anchors should be bent and blocked inside the wall. For fire sealing purposes and a perfect mechanical fit, the space between the door-frame and the masonry shall always be filled with concrete mortar.

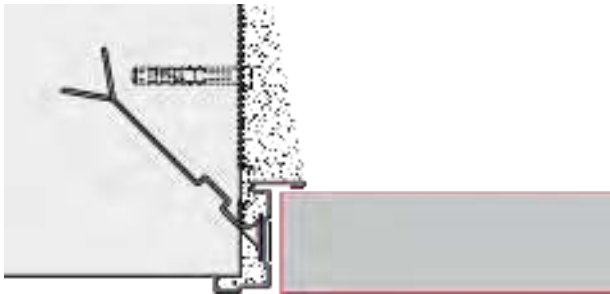

INSTALLATION FOR EXPANSION SCREWS FIXING

For the installation with expansion screws, the anchors serve as spacers and should not be bent. Using Würth type art. 0910436112 plugs or similar (supplied at the customer's expense), installation requires holes to be drilled through the thermo expansive sealing. The doorframe has pre-drilled holes. For fire sealing purposes and a perfect mechanical fit, the space between the doorframe and the masonry shall always be filled with concrete mortar.



ANCHOR POSITIONING

One-leaved doors

Right opening

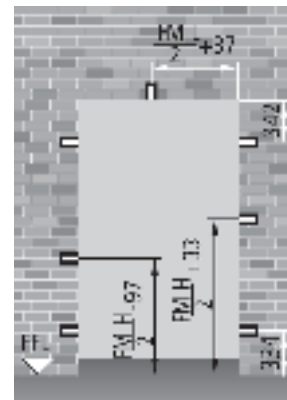

Left opening

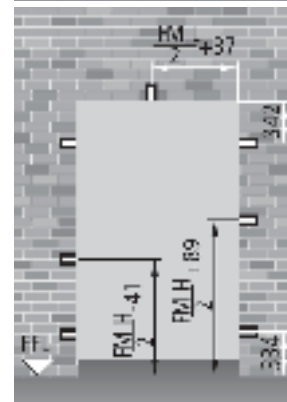

Two-leaved doors

Right opening

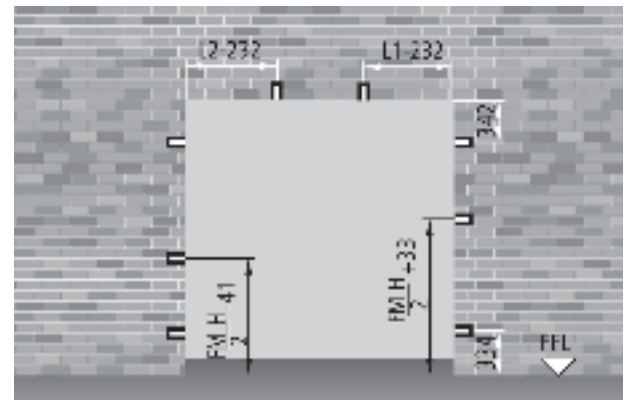

Left opening

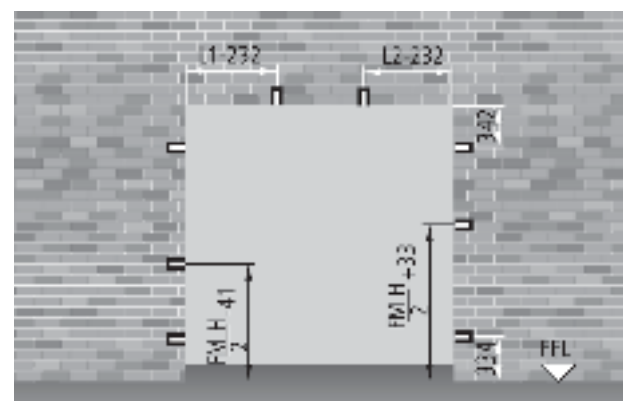

Order measurements

UNIVER Fire doors



UNIVER
fire door

ORDER MEASUREMENTS

Wall opening

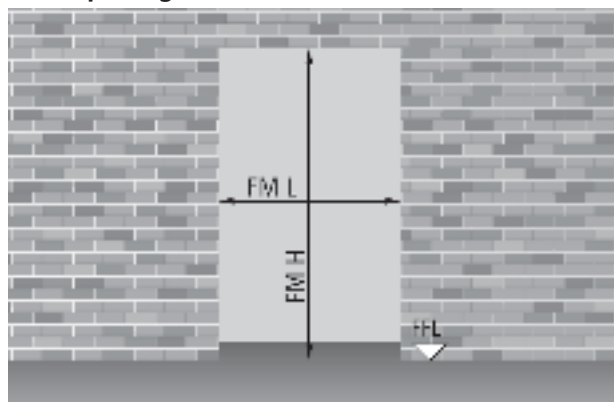

Doorframe opening

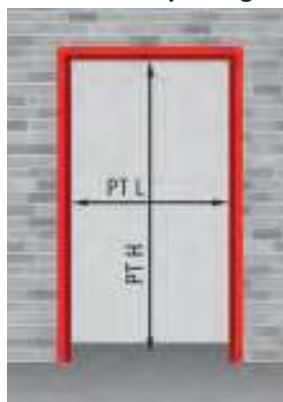

E 60 one-leaved doors FM L x FM H

PT L x PT H

fire-rating

standard dimensions			doorframe opening		class
800	x	2050 / 2100 / 2150	726	x 2010 / 2060 / 2110	E 60
900	x	2050 / 2100 / 2150	826	x 2010 / 2060 / 2110	E 60
1000	x	2050 / 2100 / 2150	926	x 2010 / 2060 / 2110	E 60
1100	x	2050 / 2100 / 2150	926	x 2010 / 2060 / 2110	E 60

non-standard dimensions

from 540 to 1150	x	from 1780 to 2150	from 466 to 1076	x from 1740 to 2110	E 60
------------------	---	-------------------	------------------	---------------------	------

EI one-leaved doors FM L x FM H

PT L x PT H

fire-rating

standard dimensions			doorframe opening		class
800	x	2050 / 2100 / 2150	726	x 2010 / 2060 / 2110	EI ₂ 60, EI ₂ 90
900	x	2050 / 2100 / 2150	826	x 2010 / 2060 / 2110	EI ₂ 60, EI ₂ 90
1000	x	2050 / 2100 / 2150	926	x 2010 / 2060 / 2110	EI ₂ 60, EI ₂ 90
1100	x	2050 / 2100 / 2150	1026	x 2010 / 2060 / 2110	EI ₂ 60

non-standard dimensions

from 540 to 1150	x	from 1780 to 2150	from 466 to 1076	x from 1740 to 2110	EI ₂ 60
from 540 to 1000	x	from 1780 to 2150	from 466 to 926	x from 1740 to 2110	EI ₂ 90

REI one-leaved doors FM L x FM H

PT L x PT H

fire-rating

standard dimensions			doorframe opening		class
800	x	2050 / 2100 / 2150	726	x 2010 / 2060 / 2110	REI 120
900	x	2050 / 2100 / 2150	826	x 2010 / 2060 / 2110	REI 120
1000	x	2050 / 2100 / 2150	926	x 2010 / 2060 / 2110	REI 120
1100	x	2050 / 2100 / 2150	1026	x 2010 / 2060 / 2110	REI 120
1200	x	2050 / 2100 / 2150	1126	x 2010 / 2060 / 2110	REI 120
1300	x	2050 / 2100 / 2150	1226	x 2010 / 2060 / 2110	REI 120
1350	x	2050 / 2100 / 2150	1276	x 2010 / 2060 / 2110	REI 120

non-standard dimensions

from 540 to 1350	x	from 1780 to 2150	from 466 to 1276	x from 1740 to 2110	REI 120
------------------	---	-------------------	------------------	---------------------	---------

Order measurements

UNIVER Fire doors



UNIVER
fire door

EI two-leaved doors FM L x FM H				PT L x PT H	H net passage	fire-rating
standard dimensions				doorframe opening	for RC/STD encumbrance	class
1200	(600 + 600)	x	2050 / 2100 / 2150	1120 x 2010 / 2060 / 2110	1990 / 2040 / 2090	EI ₂ 60
1200	(700 + 500)	x	2050 / 2100 / 2150	1120 x 2010 / 2060 / 2110	1990 / 2040 / 2090	EI ₂ 60
1300	(650 + 650)	x	2050 / 2100 / 2150	1220 x 2010 / 2060 / 2110	1990 / 2040 / 2090	EI ₂ 60
1300	(800 + 500)	x	2050 / 2100 / 2150	1220 x 2010 / 2060 / 2110	1990 / 2040 / 2090	EI ₂ 60, EI ₂ 90
1400	(700 + 700)	x	2050 / 2100 / 2150	1320 x 2010 / 2060 / 2110	1990 / 2040 / 2090	EI ₂ 60
1400	(900 + 500)	x	2050 / 2100 / 2150	1320 x 2010 / 2060 / 2110	1990 / 2040 / 2090	EI ₂ 60, EI ₂ 90
1500	(750 + 750)	x	2050 / 2100 / 2150	1420 x 2010 / 2060 / 2110	1990 / 2040 / 2090	EI ₂ 60
1500	(1000 + 500)	x	2050 / 2100 / 2150	1420 x 2010 / 2060 / 2110	1990 / 2040 / 2090	EI ₂ 60, EI ₂ 90
1600	(800 + 800)	x	2050 / 2100 / 2150	1520 x 2010 / 2060 / 2110	1990 / 2040 / 2090	EI ₂ 60, EI ₂ 90
1700	(900 + 800)	x	2050 / 2100 / 2150	1620 x 2010 / 2060 / 2110	1990 / 2040 / 2090	EI ₂ 60, EI ₂ 90
1800	(900 + 900)	x	2050 / 2100 / 2150	1720 x 2010 / 2060 / 2110	1990 / 2040 / 2090	EI ₂ 60, EI ₂ 90
1900	(1000 + 900)	x	2050 / 2100 / 2150	1820 x 2010 / 2060 / 2110	1990 / 2040 / 2090	EI ₂ 60, EI ₂ 90
2000	(1000 + 1000)	x	2050 / 2100 / 2150	1920 x 2010 / 2060 / 2110	1990 / 2040 / 2090	EI ₂ 60, EI ₂ 90
non-standard dimensions						
from 1000 (500+ 500)		x	from 1780 to 2150	from 920 to 1920 x from 1740 to 2110	from 1720 to 2090	EI ₂ 60, EI ₂ 90

REI two-leaved doors FM L x FM H				PT L x PT H	H net passage	fire-rating
standard dimensions				doorframe opening	for RC/STD encumbrance	class
1150	(750 + 400)	x	2050 / 2100 / 2150	1070 x 2010 / 2060 / 2110	1990 / 2040 / 2090	REI 120
1200	(800 + 400)	x	2050 / 2100 / 2150	1120 x 2010 / 2060 / 2110	1990 / 2040 / 2090	REI 120
1250	(800 + 450)	x	2050 / 2100 / 2150	1170 x 2010 / 2060 / 2110	1990 / 2040 / 2090	REI 120
1300	(900 + 400)	x	2050 / 2100 / 2150	1220 x 2010 / 2060 / 2110	1990 / 2040 / 2090	REI 120
1350	(900 + 450)	x	2050 / 2100 / 2150	1270 x 2010 / 2060 / 2110	1990 / 2040 / 2090	REI 120
1400	(1000 + 400)	x	2050 / 2100 / 2150	1320 x 2010 / 2060 / 2110	1990 / 2040 / 2090	REI 120
1450	(1000 + 450)	x	2050 / 2100 / 2150	1370 x 2010 / 2060 / 2110	1990 / 2040 / 2090	REI 120
1600	(800 + 800)	x	2050 / 2100 / 2150	1520 x 2010 / 2060 / 2110	1990 / 2040 / 2090	REI 120
1700	(900 + 800)	x	2050 / 2100 / 2150	1620 x 2010 / 2060 / 2110	1990 / 2040 / 2090	REI 120
1800	(900 + 900)	x	2050 / 2100 / 2150	1720 x 2010 / 2060 / 2110	1990 / 2040 / 2090	REI 120
1900	(1000 + 900)	x	2050 / 2100 / 2150	1820 x 2010 / 2060 / 2110	1990 / 2040 / 2090	REI 120
2000	(1000 + 1000)	x	2050 / 2100 / 2150	1920 x 2010 / 2060 / 2110	1990 / 2040 / 2090	REI 120
non-standard dimensions						
from 940 (540+ 400)		x	from 1780 to 2150	from 920 to 1920 x from 2011 to 2110	from 1720 to 2090	REI 120

NOTE

Unless specified otherwise by the customer, two-leaved doors are supplied with a right-pull opening direction.

Opening measurements - Overall dimensions

UNIVER Fire doors



UNIVER fire door

OPENING MEASUREMENTS AND OVERALL DIMENSIONS WITH 90 DEGREE OPENING

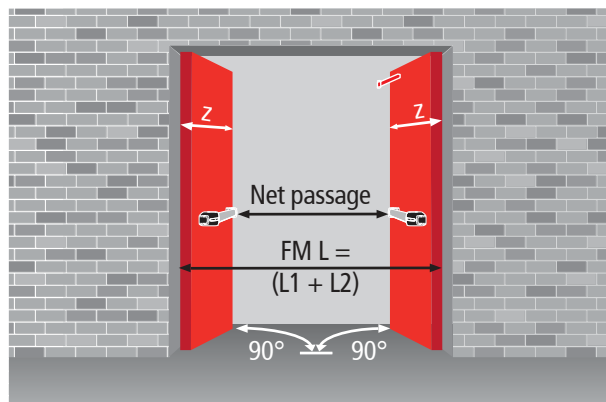
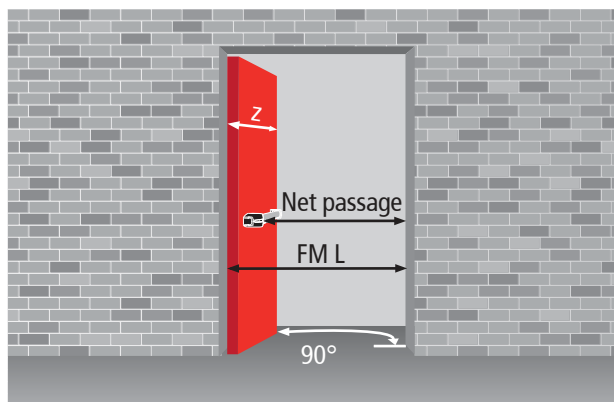

Net passage calculation

panic bar type		protrusion	E 60	EI ₂ 60 - EI ₂ 90 - REI 120	EI ₂ 60 - EI ₂ 90 - REI 120
			one-leaved doors	one-leaved doors	two-leaved doors
EXUS		125	FML - 226	FML - 236	FML - 404
TWIST		100	FML - 201	FML - 211	FML - 354
SLASH		75	FML - 176	FML - 186	FML - 304
FAST TOUCH		75	FML - 176	FML - 186	FML - 304
without panic bar		-	FML - 101	FML - 111	FML - 154
z = leaf protrusion relative to the wall			FML + 29	FML + 29	L1 + 35 L2 + 64

OVERALL DIMENSIONS WITH 180 DEGREE OPENING - HANDLE HEIGHT

One-leaved doors

$$x = FML + 5$$

$$h \text{ handle} = FMH/2 + 50$$

Two-leaved doors

$$x = L1 + 5 \quad y = L2 + 35$$

$$h \text{ handle} = FMH/2 + 50$$

b = 130 (only in the presence of panic bars or M14 handles)

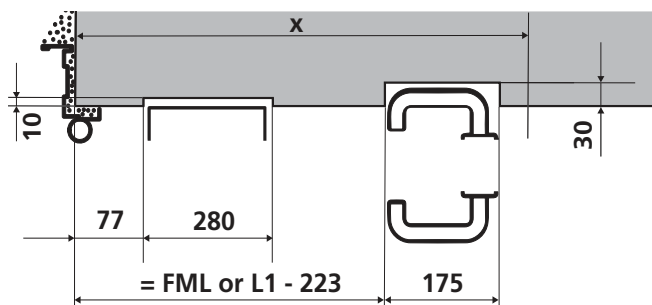
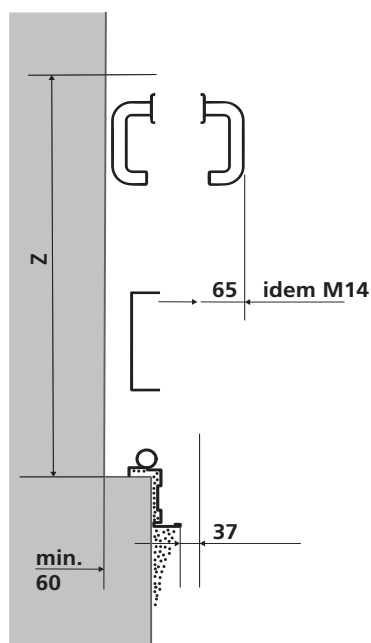
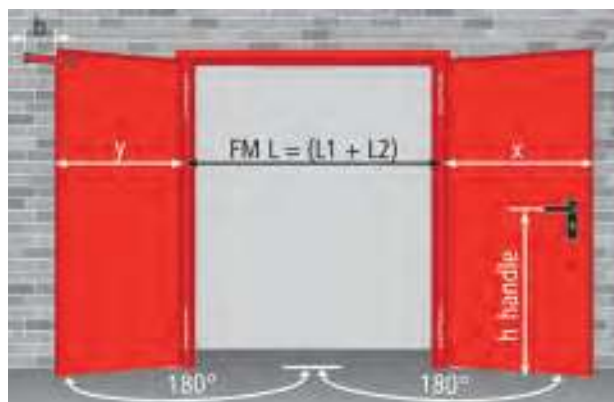

**"fire protection excellence,
flexibility custom-made"**



PROGET NINZ Doors

FIRE RATED VERSION

FEATURES	30 - 33
SPECIFIC OPTIONAL ACCESSORIES	34 - 39
ADDITIONAL PERFORMANCES	40 - 47
DOOR CROSS SECTIONS - MEASUREMENTS	48
STANDARD INSTALLATION METHOD	49
OPTIONAL INSTALLATION METHODS	50 - 51
LIGHTWEIGHT CONSTRUCTIONS INSTALLATION	52
ORDER MEASUREMENTS, HANDLE HEIGHT	53 - 54
OPENING MEASUREMENTS - OVERALL DIMENSIONS	55

THE FIRE DOOR IN A CLASS OF ITS OWN

“Indisputable quality”

- Especially sturdy door for safe functioning over time
- Ideal for application to uneven or weak walls
- Fully isolated frame for true “dry wall installation”
- Built to order for all kinds of requests
- Fully galvanized door, including the “hidden” parts
- Made of hot-galvanized sheet metal, “Sendzimir” processed
- Corrosion protection also provided along cut edges of the metal sheets
- Painted with epoxy-polyester thermoset powders in a 180 degrees (Celsius) oven
- Substantial paint layer (70 microns plus)
- Optimal corrosion resistance demonstrated by 500 hour salt-fog test
- Unaffected by severe climate changes, demonstrated by 2000 hours with +60° to -10° cycles at 75% humidity
- Finishing with high-quality aesthetics
- Orange skin anti-scratch structured paint
- Customizable with wide selection of RAL colors

“Practicality of use”

- Truly sturdy frame that facilitates anchoring to the wall
- Suitable for all wall types
- Different installation methods to choose from
- Significantly reduced installation times
- Type approvals for multiple installations to different wall types
- Ample size range
- Wide variety of accessories

“Conformity to standards”

- In-house Ninz R&D with specialized testing equipment
- Fire testing in accordance with UNI 9723 and EN 1634-1
- Mechanical testing for the **CE** marking of accessories
- **CE** marked door accessories studied and sized to meet standard European requirements
- Careful selection of materials and manufacturing methods
- Strict product testing for conformity to declared technical standards
- Absolute functional certainty over time
- Doors “type approved” in compliance with M.D. 21 June 2004
- Products delivered with the documentation required by current regulations

“Manufacturing technology”

- Manufacturing in modern and functional facilities which employ the latest technologies to maintain high quality levels and product uniformity
- The entire production process - from raw materials to painted and packaged products - takes place inside Ninz’s own facilities, ensuring a 360 degree door control

Opening direction

Opening direction needs to be indicated while ordering

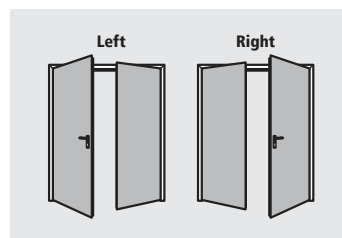
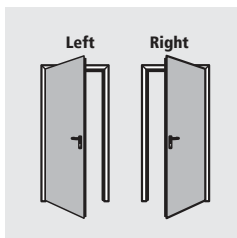

One-leaved doors available in the following classes:

EI₂60
 EI₂120
 REI 60
 REI 120
 EI₂ 60 CE



Two-leaved doors available in the following classes:

EI₂60
 EI₂90
 REI 60
 REI 120
 EI₂ 60 CE



STANDARD ELEMENTS

Door leaf

- Made of "Sendzimir" processed hot-galvanized sheet metal, press folded and electro welded
- Perimetral rebate on 3 sides, flat at the bottom
- Internally reinforced with hot-galvanized steel profiles
- Heat-insulated treated mineral wool packing that is rigidly joined to the sheet metal
- Internal stiffeners for overhead door closer and panic bar

Standard frame

- Sturdy profile with a sizeable cross section
- Made of "Sendzimir" processed hot-galvanized sheet metal
- Equipped with special assembly brackets
- Grooves for thermo expansive sealing and rebate sealing
- Standard installation via anchors for mortar fixing
- Upon request installation via expansion screws or screws onto the subframe
- Lower spacer, mounting template
- Rests on finished flooring without rebate
- Strike plates in black plastic for lock bolt and safety bolts
- Assembly required for doorframes

Thermo expansive sealing

- Mounted on vertical doorframe profiles and central vertical profiles (for two-leaved doors)
- Mounted above and below the leaves depending on the certification



Hinges

- Nr. 2 three-wing hinges for each leaf
- of which one ball-bearing hinge with screws for vertical adjustment of the leaf, **CE** marked as per EN 1935, classified for up to 160 kg load, 200.000 cycles durability, suitable for fire door use
- and one hinge with self-closing spring

Safety bolts

- Nr. 1 or 2 or 3 safety bolts applied on hinge side leaf edge

Locking mechanism

- Reversible locking mechanism with bolt and central latch for EI₂60, EI₂90 REI 60 and REI 120 doors
- Three locking point mechanism for one-leaved EI₂120 doors
- **CE** marked in conformity with EN 12209 standard
- Insert with patent key, Euro profile cylinder ready

Handle

- Fire rated handle in black plastic with steel core
- Steel installation plate with cylinder hole
- Cover plate in black plastic
- Fastener screws and patent key insert

INCLUDED ACCESSORIES

Closing regulator

- Standard two-leaved doors include an RC/STD closing regulator to ensure the correct closing sequence of the leaves, except those with environmental characteristics for which the RC2 system is mandatory (to be ordered with the door).
- CE marking in conformity with EN 1158 standard

Locking mechanism for inactive leaf

- "Flush-bolt" automatic locking of the inactive leaf
- Lever control for unlocking

Upper coupling system for the inactive leaf

- Inactive leaf lock activated device which inserts rod into the upper strike box
- Upper strike box in pierced steel with steel roller

Lower coupling system for the inactive leaf

- Vertical rod with steel point which inserts into lower strike box
- Lower floor catch (floor-mounted bushing) made of self-extinguishing black plastic with rebate stopper

Identification plate

- Metal tag with door identification data, in accordance with current regulations



Standard paint - group 01: RAL 9010



Finishing

- Standard painted with epoxy-polyester thermoset powders in a 180 degrees oven, orange skin, anti-scratch finishing
- Standard paint RAL 9010

Standard packaging

- Single leaf wrapped into stretchable polyethylene (PE) film
- Single packaging for each doorframe with stretchable polyethylene (PE) film
- Palletized on wooden pallets

<u>Door weight</u>	<u>class</u>	<u>kg/m² of wall opening</u>
1 leaf	E1,60, REI 60	37
2 leaves	E1,60, REI 60	35
1 leaf	E1,120, REI 120	42
2 leaves	E1,90, REI 120	40

NOTE

If the door ever needs to be repainted, follow the precise instructions on the "Painting" section.

INSTALLATION ONTO OTHER WALL TYPES

Other types of installation are possible, all of which have been rigorously certified and approved

- Frame for dry wall installation with expansion screws
- Frame for dry wall installation with screws onto the sub-frame
- Block frame for in the reveal application
- Embracing frame for lightweight constructions installation



OPTIONAL ACCESSORIES

A wide variety of accessories and surface finishes are available on request for maximum value enhancement of Proget doors to your own specific needs. The proper accessories can help resolve:

Safety-related needs

- Doors for panic exits (see panic bars)
- Doors for emergency exits (see emergency exit handles)
- Open doors which must be closed in case of fire (see leaf holding systems)



Installation and utilization needs

- Frame extensions
- Different kinds of floor mounted catches
- Roofing and drip steel-profile
- Special fastener screws
- Kick and protection plates in stainless steel
- Rectangular windows, standard dimensions or built to order
- Round windows
- One-leaved door with frame on four sides



Access-related control issues

- Electrically-activated lock mechanisms
- Electric handle mechanisms
- Magnetic blocking mechanisms

Performance enhancing

- Sealing
- Cylinders
- Door closers
- Special closing regulators
- Special handles

Customized finishing

- Select finishing from a wide variety of RAL colours
- NDD – Ninz Digital Decor, graphic images applied with special ink jets and protected by a transparent topcoat. Infinite varieties of customizable decorations in harmony with specific door settings
- Stainless steel handles
- Colored handles

Packaging for maximum protection

Sturdy wooden crates protect all doors and related accessories

- For NDD decorated doors
- On construction sites
- During shipping abroad
- For special transport

NOTE

Details on the optional accessories may be found in the following chapters of this brochure:

- Painting and NDD decorations
- Accessories for metal doors
- Emergency handles and panic bars



Specific optional accessories

PROGET Fire doors



WINDOW WITH FIRE RATED GLASS

Upon request all one- and two-leaved fire doors may be equipped with round or rectangular windows with fire rated stratified glass and respective window frames fixed with screws. The window frame carters are included for round window and available as an optional accessory for the rectangular one.

Limits prescribed by regulations

According to standards UNI 9723 and EN 1634-1, windows may be smaller but not larger than the test sample size, and the reverse holds true for the border strip around the window which may be wider but not thinner. The following limits correspond with these restrictions.

Borders, window position

"Border measurement" refers to the distance from the edge of the window to the wall opening of the door.



Elevation for round windows

window size	FM H	position
Ø 300	minimum 2050	Y=1600
Ø 300	less than 2050	Y=FM H - 450
Ø 400	minimum 2150	Y=1600
Ø 400	from 2050 to 2149	Y=1550
Ø 400	less than 2050	Y=FM H - 500

Elevation for rectangular windows

window dimensions L x H	FM H	position
300 x 400	minimum 2150	Z=1450
300 x 400	from 2050 to 2149	Z=1350
300 x 400	less than 2050	Z=FM H - 700
400 x 600	minimum 2150	Z=1250
400 x 600	from 2050 to 2149	Z=1150
400 x 600	less than 2050	Z=FM H - 900
400 x 1200	minimum 2150	Z=650
400 x 1200	from 2050 to 2149	Z=550
400 x 1200	less than 2050	Z=FM H - 1500

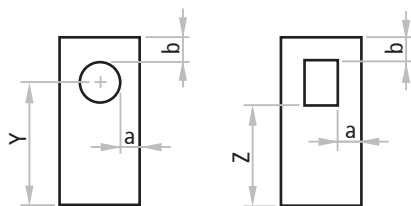

NOTE

Position and measurements indicated above are those standard.

Different positions and measurements may be considered as long as they respect the minimum "a" and "b" border strips and maximal measurements mentioned in the certificate for the window. The window itself may not be supplied separately except for replacements. It is always advisable for doors with windows to be equipped with door closers for controlled closing.

NOTE

For the rectangular windows the frame carters are an optional accessory

Round window cross section

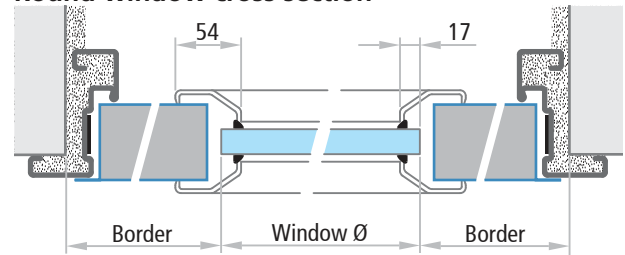

Rectangular window cross section

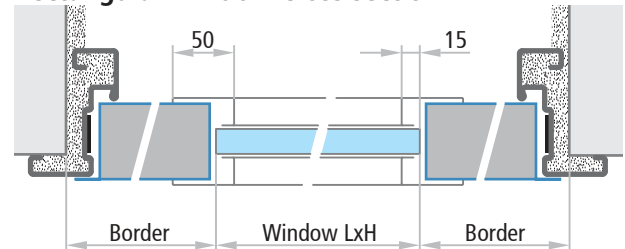

ATTENTION

For special instructions and recommendations for glazed fire-rated products, see the "Notices" section on the last page of the present brochure.

Specific optional accessories

PROGET Fire doors



EI WINDOW SPECIFICATIONS BASED ON INSTALLATION METHOD

model	min./max. window		border strip		mortar fixing	expansion screws	lightweight constructions with embracing frame	block frame	EI,60	EI,90	EI,120	dimensions FM L (L1 + L2) x FM H
	L	x	H	a								
	Ø 300		300	300	✓	✓	✓	✓	✓			from 900 to 1340 x from 1950 to 2600
	Ø 400		300	300	✓	✓	✓	✓	✓			from 1000 to 1340 x from 1950 to 2600
	Ø 300		300	300	✓	✓		✓			✓	from 900 to 1340 x from 1900 to 2640
	Ø 400		300	300	✓	✓		✓			✓	from 1000 to 1340 x from 1900 to 2640
	from 250 to 700	from 250 to 650	300	300	✓	✓	✓		✓			from 850 to 1340 x from 1950 to 2600
	from 250 to 670	from 250 to 620	300	300				✓	✓			from 850 to 1340 x from 1950 to 2600
	from 250 to 600	from 250 to 400	370	300	✓	✓		✓			✓	from 990 to 1340 x from 1900 to 2640
	Ø 300		300	300	✓	✓	✓	✓	✓			from 1250 (900 + 350) to 2540 (1270 + 1270) x from 1775 to 2600
	Ø 400		300	300	✓	✓	✓	✓	✓			from 1350 (1000 + 350) to 2540 (1270 + 1270) x from 1775 to 2600
	Ø 300		300	300	✓	✓		✓			✓	from 1475 (900 + 575) to 2270 (1150 + 1120) x from 1775 to 2300
	Ø 400		300	300	✓	✓		✓			✓	from 1575 (1000 + 575) to 2270 (1150 + 1120) x from 1775 to 2300
	Ø 300		300	300	✓	✓	✓	✓	✓			from 1800 (900 + 900) to 2540 (1270 + 1270) x from 1775 to 2600
	Ø 400		300	300	✓	✓	✓	✓	✓			from 2000 (1000 + 1000) to 2540 (1270 + 1270) x from 1775 to 2600
	Ø 300		300	300	✓	✓		✓			✓	from 1800 (900 + 900) to 2270 (1150 + 1120) x from 1775 to 2300
	Ø 400		300	300	✓	✓		✓			✓	from 2000 (1000 + 1000) to 2270 (1150 + 1120) x from 1775 to 2300
	from 250 to 700	from 250 to 650	300	300	✓	✓	✓		✓			from 1200 (850 + 350) to 2540 (1270 + 1270) x from 1775 to 2600
	from 250 to 670	from 250 to 620	300	300				✓	✓			from 1200 (850 + 350) to 2540 (1270 + 1270) x from 1775 to 2600
	from 250 to 600	from 250 to 400	300	300	✓	✓		✓			✓	from 1425 (850 + 575) to 2270 (1150 + 1120) x from 1775 to 2300
	from 250 to 700	from 250 to 650	300	300	✓	✓	✓		✓			from 1700 (850 + 850) to 2540 (1270 + 1270) x from 1775 to 2600
	from 250 to 670	from 250 to 620	300	300				✓	✓			from 1700 (850 + 850) to 2540 (1270 + 1270) x from 1775 to 2600
	from 250 to 600	from 250 to 400	300	300	✓	✓		✓			✓	from 1700 (850 + 850) to 2270 (1150 + 1120) x from 1775 to 2300

Specific optional accessories

PROGET Fire doors



PROGET
fire doors

REI WINDOW SPECIFICATIONS BASED ON INSTALLATION METHOD

model	min./max. window			border strip		mortar fixing subframe	expansion screws	plasterboard with embracing frame	REI 60	REI 120	dimensions FM L (L1 + L2) x FM H
	L	x	H	a	b						
	Ø 300			300	300		✓	✓	✓	✓	from 900 to 1170 x from 1775 to 2275 from 1004 to 1340 x from 2050 to 2500
	Ø 400			300	300		✓	✓	✓	✓	from 1000 to 1170 x from 1775 to 2275 from 1004 to 1340 x from 2050 to 2500
	from 250 to 400	from 250 to 600	250	300	✓					✓	from 750 to 900 x from 1775 to 2000
	from 250 to 400	from 250 to 600	300	300	✓					✓	from 850 to 1000 x from 1775 to 2150
	from 250 to 620	from 250 to 400	360	300	✓					✓	from 970 to 1340 x from 1775 to 2670
	from 250 to 564	from 250 to 443	300	300		✓	✓	✓	✓	✓	from 850 to 1170 x from 1775 to 2275 from 1004 to 1340 x from 2050 to 2500
	from 250 to 400	from 630 to 1400	250	300	✓					✓	from 750 to 900 x from 1775 to 2000 from 779 to 1037 x from 1803 to 2197
	from 250 to 522	from 500 to 1460	320	300	✓					✓	from 890 to 1162 x from 1775 to 2620 from 997 to 1332 x from 2361 to 2670
	Ø 300			300	300		✓	✓	✓	✓	from 1250 (900 + 350) to 2252 (1126 + 1126) x from 1775 to 2275** from 1962 (996 + 966) to 2540 (1270 + 1270) x from 2050 to 2500
	Ø 400			300	300		✓	✓	✓	✓	from 1350 (1000 + 350) to 2252 (1126 + 1126) x from 1775 to 2275** from 1966 (1000 + 966) to 2540 (1270 + 1270) x from 2050 to 2500
	Ø 300			300	300		✓	✓	✓	✓	from 1800 (900 + 900) to 2252 (1126 + 1126) x from 1775 to 2275 from 1962 (996 + 966) to 2540 (1270 + 1270) x from 2050 to 2500
	Ø 400			300	300		✓	✓	✓	✓	from 2000 (1000 + 1000) to 2252 (1126 + 1126) x from 1775 to 2275 from 2000 (1000 + 1000) to 2540 (1270 + 1270) x from 2050 to 2500
	from 250 to 400	from 250 to 600	300	300	✓					✓	from 1200 (850 + 350) to 2000 (1000 + 1000) x from 1775 to 2150**
	from 250 to 400	from 250 to 600	300	300	✓					✓	from 1700 (850 + 850) to 2000 (1000 + 1000) x from 1775 to 2150
	from 250 to 620	from 250 to 400	325	300	✓					✓	from 1250 (900 + 350) to 2540 (1270 + 1270) x from 1775 to 2670**
	from 250 to 620	from 250 to 400	325	300	✓					✓	from 1800 (900 + 900) to 2540 (1270 + 1270) x from 1775 to 2670
	from 250 to 564	from 250 to 443	300	300		✓	✓	✓	✓	✓	from 1200 (850 + 350) to 2252 (1126 + 1126) x from 1775 to 2275** from 1962 (996 + 966) to 2540 (1270 + 1270) x from 2050 to 2500
	from 250 to 564	from 250 to 443	300	300		✓	✓	✓	✓	✓	from 1700 (850 + 850) to 2252 (1126 + 1126) x from 1775 to 2275 from 1962 (996 + 966) to 2540 (1270 + 1270) x from 2050 to 2500
	from 250 to 400	from 630 to 1400	250	300	✓					✓	from 1100 (750 + 350) to 1800 (900 + 900) x from 1775 to 2000 from 1539 (772 + 767) to 2061 (1028 + 1033) x from 1803 to 2197
	from 250 to 515	from 500 to 1460	320	300	✓					✓	from 1240 (890 + 350) to 2315 (1155 + 1160) x from 1775 to 2620 from 1975 (989 + 986) to 2540 (1268 + 1272) x from 2361 to 2670

NOTE

(*) Windows only possible for the minimum size of 0,25m², and only on one-leaved doors or the active leaf of two-leaved doors.

(**) FM inactive leaf minimum without window with RC/STD =350mm. FM inactive leaf minimum without window but with RC2=370mm.

Specific optional accessories

PROGET Fire doors



PROGET fire doors

FRAME EXTENSIONS FOR PROGET DOORS

IM 1

Frame extension to be mounted in addition to the Proget frame to serve as embracing frame made of "Sendzimir" processed hot-galvanized sheet metal and painted the same color as the doorframe with epoxy-polyester powders. Profile on three sides, upper corners with 45 degree joint, fixing with screws and plugs in groove (screws and plugs not included).

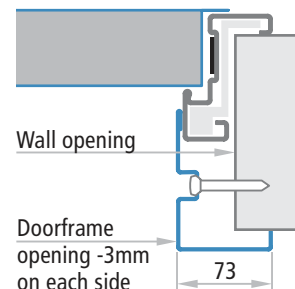
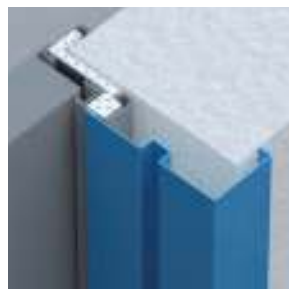

IM 3

Frame extension to be mounted in addition to the Proget frame to serve as embracing frame, especially for EI₂90, EI₂120 with installation for expansion screws fixing. Made of "Sendzimir" processed hot-galvanized sheet metal and painted the same color as the doorframe with epoxy-polyester powders. Profile on three sides, upper corners with 45 degree joint, fixing with screws and plugs (screws and plugs not included).

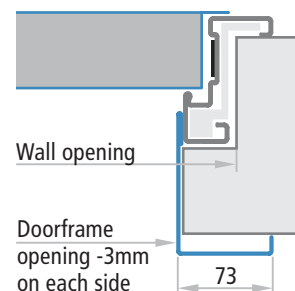

IM 4

Frame extension to be screwed to the Proget doorframe acting as a wall cladding. Made of "Sendzimir" processed hot-galvanized sheet metal painted the same color as the doorframe with epoxy-polyester powders. Profile on three sides, upper corners with 90 degree joint. Complete with fastener screws. To mount the frame extension, pre-drilled holes are available on the frame. Combine with sealing to conceal the screw heads.

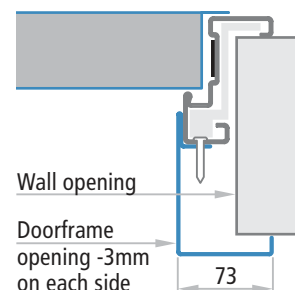

IM 5

Telescopic frame extension to be screwed to the Proget doorframe acting as a wall cladding for expansion screw fixing. Consists of two overlapping profiles with a 25mm adjustable range. Made of "Sendzimir" processed hot-galvanized sheet metal painted the same color as the doorframe with epoxy-polyester powders. Profile on three sides, upper corners with 90 degree joint. Complete with fastener screws. To mount the frame extension, pre-drilled holes are available on the frame. Combine with sealing to conceal the screw heads.

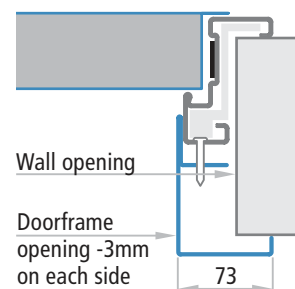

FRAME ON FOUR SIDES

Upon request one-leaved Proget doors may be supplied with frames on four sides and leaves with or without lower rebate. These type of doors are used mainly for technical rooms or shafts.

The frame on four sides is not available for the following applications: doors installed onto escape routes, two-leaved doors, doors with environmental characteristics, application on lightweight constructions, in combination with frame extensions.

ATTENTION

With the frame on four sides, the center of the handle will be 15 mm higher than the standard position. For more details, see the page "Door cross section - Measurements".

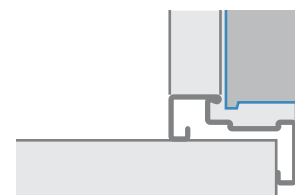

Leaf with lower rebate

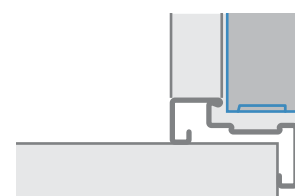

Leaf without lower rebate

Specific optional accessories

PROGET Fire doors



PROGET
fire doors

THREE-POINT LOCKING MECHANISM

Mandatory for one-leaved EI₂120 doors and upon request for a more reliable closure of one- and two-leaved EI₂60 and two-leaved EI₂90 doors. In combination with double M1 handle and cylinder. The lock is also available for anti-panic and emergency push versions. Thus the three-point locking mechanism can be combined with emergency handles or with EXUS, TWIST, SLASH type BM panic bars in conformity with CE marking.

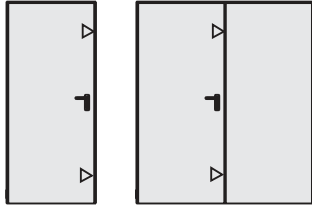

▷ Additional closure points

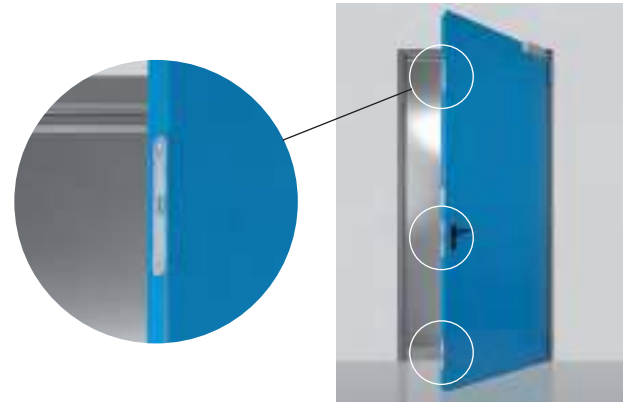

NOTE

Three point locking mechanism can be combined with M1, M1C, M1X, M1Xs, M11, M11X, M11Xs handles only.

STEEL FLOOR CATCH

Floor-mounted steel floor catch for two-leaved Proget doors. Made of pierced and successively galvanized steel. Includes rebate stop for the inactive leaf, the strike box for insertion of the rod, Nr. 3 screws and Nr. 3 plugs. To be used in place of the plastic floor catch for doors that usually remain open and where carts and heavy equipment pass on a regular basis.

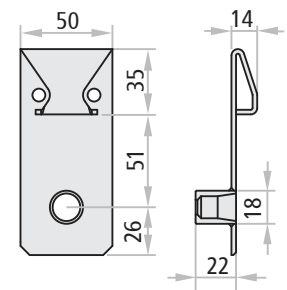

Lower PROGET steel floor catch

RETREATING FLOOR CATCH „N626“

To be applied in combination with two-leaved PROGET doors, which are usually to be kept open, in substitution of the standard floor catch. The N626's advantage is the embedding of the floor catch into the floor which is activated only by the closing of the inactive leaf. Thus when the doors are open protrusions are avoided guaranteeing nevertheless a correct closing.



NOTE

For the passing of the cable of the command function the installation into the floor of a wrinkled cable sleeve is necessary. The installation of the N626 requires trained personnel.

Specific optional accessories

PROGET Fire doors



PROGET
fire doors

REBATE SEALING

CR sealing (for EI₂ doors) and sealing (for REI doors) in black extruded profile to cut and to be pressed into the dedicated groove in the perimetral frame and on the central joint of two-leaved doors.



THRESHOLD

Fixed threshold in anodized aluminium supplied with relative rebate sealing. To be installed for single and double leaved doors onto the floor with screws and plugs (not supplied).

NOTE

For the installation it is necessary to adapt the threshold to the frame of the door and to drill a hole for its fixing. Further it is necessary to finish up the threshold with silicone.

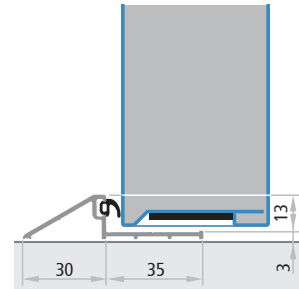

Additional performances

PROGET Fire doors



INTERNAL PEDESTRIAN DOORS

Classification report NO. IFT 16-000122-PR03

Test report NO. IFT 12-001195-PR01



Pedestrian interior doors are not yet subject to marking as the relevant standard EN 14351-2 has not yet entered into force. The performances contained in the standard can however be a reference for classifying the door for indoor, such as:

- air permeability according to EN 1026:2001
- thermal transmittance according to EN ISO 10077-1:2018 e EN ISO 10077-2:2018

PROGET fire doors are also classified as Sa or S200 for smoke control according to EN 1634-3 (test method) and 13501-2 (classification).

The price list lists the Combos which add these additional performances to the door.

ATTENTION

For the dimensional limits according to the certificates and homologations of the fire rated doors and regarding the minimum borders please refer to the specific pages of this brochure.

The values for the thermal transmittance W/m^2K shown in the table on the next page are given by the calculation according to the norm EN ISO 10077-1 done on samples of the dimensions 1,23x2,18 for areas $\leq 3,6m^2$ and on samples of the dimensions 2,00x2,18 for areas $> 3,6m^2$.

All performance values indicated in the table are valid only in presence of the following accessories or enhancements:

- standard frame to be installed with wall anchors and mortar or with screws and plugs
- embracing frame prepared for the installation onto lightweight constructions
- isolation of the frame with the filling of cement or plasterboard
- installation of rubber seals along the entire perimeter of the door frame including the central rebate for double leaved doors
- presence of the automatic door sweep depending upon selected solution.

In case of windows with dimensions larger than those tested (300x400mm), up to a maximum size of 400x600mm the differing performance value for the thermal transmittance needs to be asked, the performance value for acoustic isolation remains unchanged.

For the acoustic isolation performance values, in case of asymmetric double leaved doors ($L1 \neq L2$), select the minor R_w value of the two (example 1: leaf without windows and $H=2150$, $L1=1000$, $L2=500$ select 32 dB; example 2: leaf without windows and $H=2150$, $L1=1200$, $L2=1000$ select 35 dB).



SMOKE CONTROL ACCORDING TO EN 1634-3

This is the ability of one element to reduce or eliminate the passage of smoke from one side of the door to the other. Two levels of smoke performance are defined.

Smoke control Sa: when the maximum dispersion value measured at room temperature and at a pressure of 25 Pascal is not greater than $3 m^3/h$ per metre of the gap between the door frame and the door frame excluding loss through the floor threshold.

Smoke control S200: when the maximum dispersion value, measured at room temperature and 200 C and up to a pressure of 50 Pascal, is not greater than $20 m^3/h$ for a single door or $30 m^3/h$ for a two-door door.

The smoke tightness is verified with a specific technical test in accordance with UNI EN 1634-3, while the classification is provided by UNI EN 13501-2 according to the following criteria:

Sa considers only the seal at room temperature

S200 considers the seal at room temperature and at 200 C



Additional performances

PROGET Fire doors



PROGET
fire doors

INTERNAL PEDESTRIAN DOORS

Classification report NO. IFT 16-000122-PR03

Test report NO. IFT 12-001195-PR01



Type	FM L x H	Class	std angular frame	installation with screw or expansions screws	embracing frame	Combo Thermo/GS - Combo Thermo/GSV Combo dB Sa/GS - Combo dB Sa/GSV version with rebate sealing CR and automatic door sweep Combo S200/GS - Combo S200/GSV version with rebate sealing CR and automatic door sweep and three-point locking mechanism				Combo Thermo - Combo Sa version with rebate sealing CR			
						smoke control according to UNI EN 1634-3	air permeability according to UNI EN 1026:2001	thermal transmittance according to UNI EN 10077-1:2018 UNI EN 10077-2:2018	acoustic performance according to UNI EN ISO 140-3	smoke control according to UNI EN 1634-3	air permeability according to UNI EN 1026:2001	thermal transmittance according to UNI EN 10077-1:2018	
without window	≤ 3,6 m ²	REI 60-EI ₂ 60	✓			Sa S200 classe 2		1,4 W/m ² K		Sa		1,3 W/m ² K	
	≤ 3,6 m ²	REI 60-EI ₂ 60		✓		Sa S200 classe 2		1,3 W/m ² K		Sa		1,3 W/m ² K	
	≤ 3,6 m ²	REI 60-EI ₂ 60			✓	Sa S200 classe 2		1,5 W/m ² K		Sa		1,5 W/m ² K	
	≤ 3,6 m ²	REI 120-EI ₂ 90/120	✓			Sa S200 classe 2		1,4 W/m ² K		Sa		1,4 W/m ² K	
	≤ 3,6 m ²	REI 120-EI ₂ 90/120		✓		Sa S200 classe 2		1,4 W/m ² K		Sa		1,3 W/m ² K	
	≤ 3,6 m ²	REI 120-EI ₂ 90/120			✓	Sa S200 classe 2		1,5 W/m ² K		Sa		1,5 W/m ² K	
	800 - 1100 x 2000 - 2250	REI 120-EI ₂ 90/120	✓	✓	✓				Rw = 36 dB				
	1101 - 1340 x 2000 - 2250	REI 120-EI ₂ 90/120	✓	✓	✓				Rw = 35 dB				
800 - 1340 x 2251 - 2670	REI 120-EI ₂ 90/120	✓	✓	✓				Rw = 34 dB					
with window 300x400	≤ 3,6 m ²	REI 60-EI ₂ 60	✓			Sa S200 classe 2		1,9 W/m ² K		Sa		1,9 W/m ² K	
	≤ 3,6 m ²	REI 60-EI ₂ 60		✓		Sa S200 classe 2		1,9 W/m ² K		Sa		1,9 W/m ² K	
	≤ 3,6 m ²	REI 60-EI ₂ 60			✓	Sa S200 classe 2		2,1 W/m ² K		Sa		2,0 W/m ² K	
	≤ 3,6 m ²	REI 120-EI ₂ 90/120	✓			Sa S200 classe 2		1,9 W/m ² K		Sa		1,9 W/m ² K	
	≤ 3,6 m ²	REI 120-EI ₂ 90/120		✓		Sa S200 classe 2		1,8 W/m ² K		Sa		1,8 W/m ² K	
	≤ 3,6 m ²	REI 120-EI ₂ 90/120			✓	Sa S200 classe 2		2,0 W/m ² K		Sa		2,0 W/m ² K	
	800 - 1100 x 2000 - 2250	REI 120-EI ₂ 90/120	✓	✓	✓				Rw = 36 dB				
	1101 - 1340 x 2000 - 2250	REI 120-EI ₂ 90/120	✓	✓	✓				Rw = 35 dB				
800 - 1340 x 2251 - 2670	REI 120-EI ₂ 90/120	✓	✓	✓				Rw = 34 dB					
without window	≤ 3,6 m ²	REI 60-EI ₂ 60	✓			Sa S200 classe 3		1,8 W/m ² K		Sa		1,8 W/m ² K	
	> 3,6 m ²	REI 60-EI ₂ 60	✓			Sa S200 classe 3		1,5 W/m ² K		Sa		1,4 W/m ² K	
	≤ 3,6 m ²	REI 60-EI ₂ 60		✓		Sa S200 classe 3		1,8 W/m ² K		Sa		1,7 W/m ² K	
	> 3,6 m ²	REI 60-EI ₂ 60		✓		Sa S200 classe 3		1,4 W/m ² K		Sa		1,4 W/m ² K	
	≤ 3,6 m ²	REI 60-EI ₂ 60			✓	Sa S200 classe 3		1,9 W/m ² K		Sa		1,9 W/m ² K	
	> 3,6 m ²	REI 60-EI ₂ 60			✓	Sa S200 classe 3		1,6 W/m ² K		Sa		1,5 W/m ² K	
	≤ 3,6 m ²	REI 120-EI ₂ 90/120	✓			Sa S200 classe 3		1,8 W/m ² K		Sa		1,8 W/m ² K	
	> 3,6 m ²	REI 120-EI ₂ 90/120	✓			Sa S200 classe 3		1,5 W/m ² K		Sa		1,5 W/m ² K	
	≤ 3,6 m ²	REI 120-EI ₂ 90/120		✓		Sa S200 classe 3		1,8 W/m ² K		Sa		1,8 W/m ² K	
	> 3,6 m ²	REI 120-EI ₂ 90/120		✓		Sa S200 classe 3		1,5 W/m ² K		Sa		1,4 W/m ² K	
	≤ 3,6 m ²	REI 120-EI ₂ 90/120			✓	Sa S200 classe 3		2,0 W/m ² K		Sa		1,9 W/m ² K	
	> 3,6 m ²	REI 120-EI ₂ 90/120			✓	Sa S200 classe 3		1,6 W/m ² K		Sa		1,6 W/m ² K	
	FM min 1000 (L1/L2 max 799) x 2000 - 2670	REI 120-EI ₂ 90/120	✓	✓	✓					Rw = 32 dB			
	(L1 o L2) 800 - 1100 x 2000 - 2250	REI 120-EI ₂ 90/120	✓	✓	✓					Rw = 36 dB			
(L1 o L2) 1101 - 1330 x 2000 - 2250	REI 120-EI ₂ 90/120	✓	✓	✓					Rw = 35 dB				
(L1 o L2) 800 - 1330 x 2251 - 2670	REI 120-EI ₂ 90/120	✓	✓	✓					Rw = 34 dB				
with window 300x400	≤ 3,6 m ²	REI 60-EI ₂ 60	✓			Sa S200 classe 3		2,3 W/m ² K		Sa		2,3 W/m ² K	
	> 3,6 m ²	REI 60-EI ₂ 60	✓			Sa S200 classe 3		2,1 W/m ² K		Sa		2,1 W/m ² K	
	≤ 3,6 m ²	REI 60-EI ₂ 60		✓		Sa S200 classe 3		2,3 W/m ² K		Sa		2,3 W/m ² K	
	> 3,6 m ²	REI 60-EI ₂ 60		✓		Sa S200 classe 3		2,1 W/m ² K		Sa		2,0 W/m ² K	
	≤ 3,6 m ²	REI 60-EI ₂ 60			✓	Sa S200 classe 3		2,5 W/m ² K		Sa		2,4 W/m ² K	
	> 3,6 m ²	REI 60-EI ₂ 60			✓	Sa S200 classe 3		2,2 W/m ² K		Sa		2,2 W/m ² K	
	≤ 3,6 m ²	REI 120-EI ₂ 90/120	✓			Sa S200 classe 3		2,3 W/m ² K		Sa		2,3 W/m ² K	
	> 3,6 m ²	REI 120-EI ₂ 90/120	✓			Sa S200 classe 3		2,1 W/m ² K		Sa		2,0 W/m ² K	
	≤ 3,6 m ²	REI 120-EI ₂ 90/120		✓		Sa S200 classe 3		2,3 W/m ² K		Sa		2,2 W/m ² K	
	> 3,6 m ²	REI 120-EI ₂ 90/120		✓		Sa S200 classe 3		2,0 W/m ² K		Sa		2,0 W/m ² K	
	≤ 3,6 m ²	REI 120-EI ₂ 90/120			✓	Sa S200 classe 3		2,4 W/m ² K		Sa		2,4 W/m ² K	
	> 3,6 m ²	REI 120-EI ₂ 90/120			✓	Sa S200 classe 3		2,2 W/m ² K		Sa		2,1 W/m ² K	
	FM min 1000 (L1/L2 max 799) x 2000 - 2670	REI 120-EI ₂ 90/120	✓	✓	✓					Rw = 32 dB			
	(L1 o L2) 800 - 1100 x 2000 - 2250	REI 120-EI ₂ 90/120	✓	✓	✓					Rw = 36 dB			
(L1 o L2) 1101 - 1330 x 2000 - 2250	REI 120-EI ₂ 90/120	✓	✓	✓					Rw = 35 dB				
(L1 o L2) 1101 - 1330 x 2000 - 2250	REI 120-EI ₂ 90/120	✓	✓	✓					Rw = 34 dB				

Additional performances

PROGET Fire doors



PROGET
fire doors

EXTERNAL PEDESTRIAN DOORS

Certificate CE 1404 - CPR -3737

EN 16034:2014 - EN 14351-1:2006+A2:2016



According to standards EN 16034 and EN 14351-1, an external door is defined as a door that separates the internal climate from the external environment of a building. For this application, doors must be CE marked in accordance with EN 16034:2014 and EN 14351-1:2006+A2:2016. Furthermore, if the door is installed along an escape route and equipped with a panic or emergency exit device, it is also subject to the assessment and verification of constancy of performance under "System 1". This requires the manufacturer to hold a Certificate of Constancy of Performance issued by a Notified Body — for NINZ S.p.A., this is certificate 1404 - CPR - 3737.

Proget fire doors for external use must be ordered with the specific CE Combo Est options available in the Proget fire door price list, selected based on the essential requirements indicated in the tables on the following pages, and considering those that are mandatory according to the applicable national regulations. This ensures that each door is provided with the required CE marking and the documentation specified by the current legislation.

ATTENTION

For dimensional limits, minimum edge requirements and production options, please refer to the specific pages of this catalogue. The thermal transmittance values (W/m²K) shown in the tables on the following pages are calculated in accordance with EN ISO 10077-1, applied to samples measuring 1.23 x 2.18 m for areas ≤ 3.6 m² and to samples measuring 2.00 x 2.18 m for areas > 3.6 m². All performance values listed in the table are valid only if the door is installed with the following accessories and measures:

- presence of a bottom rebate threshold
- in case of installation along an escape route, the floor on the push side must be raised to fully level the gap between the floor and the bottom threshold
- frame insulation by filling with polyurethane foam or cement-based mortar
- application of sealing gaskets along the entire perimeter of the frame and on the central mullion in double-leaf doors
- sealing of the frame's perimeter edge (on the push side) with neutral silicone
- for doors with vision panels: installation of external fire-resistant glazing sized 300x400 mm

In case of windows up to a maximum size of max 400x600mm the differing performance value for the thermal transmittance needs to be asked, all other performance values remain unchanged.

For the acoustic isolation performance values, in case of asymmetric double leaved doors (L1≠L2), select the minor Rw value of the two.

- example 1: leaf without windows and H=2150, L1=1000, L2= 500 select 30 dB;
- example 2: leaf without windows and H=2150, L1=1200, L2=1000 select 32 dB.



Certificate
of constancy of performance

1404 – CPR – 3737



ZAVOD ZA
GRADBENIŠTVO
SLOVENIJE
SI OVEŠTAN
NATIONAL BUILDING
AND CIVIL ENGINEERING
INSTITUTE
Drobova ulica 12
1000 Ljubljana
Slovenija
info@zag.si
www.zag.si
Notified certification body
NB 1404

In compliance with Regulation (EU) No 305/2011 of the European Parliament and of the Council of 9 March 2011 (the Construction Products Regulation or CPR), this certificate applies to the construction product

Single and double leaf fire door PROGET EI 60
(doors that fall within the scope of standard EN 14351-1:2006+A2:2016)

placed on the market under the name or trade mark of

NINZ S.p.A.,
Corso Trento 2, 38061 Ala (TN), Italy

and produced in the manufacturing plants

NINZ S.p.A.,
Corso Trento 2, 38061 Ala (TN), Italy

and
NINZ S.p.A.,
Via Negrelli 17, 39100 Bolzano, Italy.

This certificate attests that all provisions concerning the assessment and verification of constancy of performance described in Annex ZA of the standards

EN 16034:2014 and EN 14351-1:2006+A2:2016

under system 1 for the performance set out in this certificate are applied and that the factory production control conducted by the manufacturer is assessed to ensure the

constancy of performance of the construction product.

This certificate was first issued on 4. 6. 2024 and will remain valid until 4. 6. 2029 as long as neither the harmonised standards, the construction products, the AVCP method nor the manufacturing conditions in the plant are modified significantly, unless suspended or withdrawn by the notified product certification body.

Detailed information about the scope of the product is given in the annex to this certificate.

Ljubljana, 4. 6. 2024

Authorised signatory of the Certification body:
mag. Egon Miloš, univ.dipl.inž.grad.

ZAG-001-308-2v1

This certificate has a total of 2 pages

Certificate No. 1404 – CPR – 3737, issue 1

NOTES

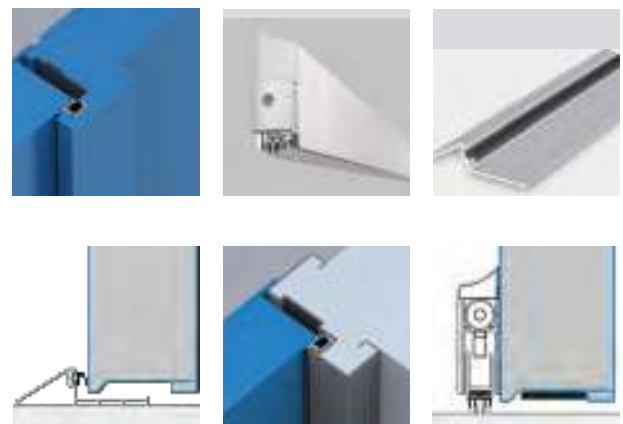

For information regarding outdoor installation, please refer to the "Warnings" section on the last page of this catalogue.



Additional performances

PROGET Fire doors



PROGET Fire Door EI ₂ 60		 Angular frame Embracing frame. Tunnel frame			Combo with CR rebate gasket and door closer for C5 version		Combo with CR rebate gasket, drop-down seal and door closer for C5 version	
					CE	CE C5	CE Sa/SF	CE Sa/SF C5
Without windows 	EN 16034:2014							
	Fire resistance	✓	✓	✓	EI ₂ 60	EI ₂ 60	EI ₂ 60	EI ₂ 60
	Smoke control	✓	✓	✓	N.P.D.	N.P.D.	Sa	Sa
	Ability to release / lock	✓	✓	✓	N.P.D.	N.P.D.	N.P.D.	N.P.D.
	Self-closing	✓	✓	✓	C	C	C	C
	Durability of release mechanism	✓	✓	✓	N.P.D.	N.P.D.	N.P.D.	N.P.D.
	Durability of self-closing							
	- against degradation	✓	✓	✓	0	5	0	5
	- against corrosion	✓	✓	✓	N.P.D.	N.P.D.	N.P.D.	N.P.D.
	EN 14351-1:2006+A2:2016							
	Air permeability	✓	✓	✓	N.P.D.	N.P.D.	2	2
	Water tightness	✓	✓	✓	N.P.D.	N.P.D.	1A	1A
	Wind load resistance							
	- door with FM ≤ 1140x2150	✓	✓	✓	N.P.D.	N.P.D.	C1	C1
	- door with FM > 1140x2150	✓	✓	✓	N.P.D.	N.P.D.	N.P.D.	N.P.D.
	Impact resistance	✓	✓	✓	N.P.D.	N.P.D.	N.P.D.	N.P.D.
	Load-bearing capacity of safety devices	✓	✓	✓	Exceeds	Exceeds	Exceeds	Exceeds
	Acoustic performance	✓	✓	✓	N.P.D.	N.P.D.	N.P.D.	N.P.D.
	Thermal transmittance	✓			1,30 W/m ² K	1,30 W/m ² K	1,40 W/m ² K	1,40 W/m ² K
	Thermal transmittance		✓		1,50 W/m ² K	1,50 W/m ² K	1,50 W/m ² K	1,50 W/m ² K
	Thermal transmittance			✓	1,50 W/m ² K	1,50 W/m ² K	1,50 W/m ² K	1,50 W/m ² K
	Ability to release / open	✓	✓	✓	N.P.D.	N.P.D.	N.P.D.	N.P.D.
	With windows 300x400 	EN 16034:2014						
Fire resistance		✓	✓	✓	EI ₂ 60	EI ₂ 60	EI ₂ 60	EI ₂ 60
Smoke control		✓	✓	✓	N.P.D.	N.P.D.	Sa	Sa
Ability to release / lock		✓	✓	✓	N.P.D.	N.P.D.	N.P.D.	N.P.D.
Self-closing		✓	✓	✓	C	C	C	C
Durability of release mechanism		✓	✓	✓	N.P.D.	N.P.D.	N.P.D.	N.P.D.
Durability of self-closing								
- against degradation		✓	✓	✓	0	5	0	5
- against corrosion		✓	✓	✓	N.P.D.	N.P.D.	N.P.D.	N.P.D.
EN 14351-1:2006+A2:2016								
Air permeability		✓	✓	✓	N.P.D.	N.P.D.	2	2
Water tightness		✓	✓	✓	N.P.D.	N.P.D.	1A	1A
Wind load resistance								
- door with FM ≤ 1140x2150		✓	✓	✓	N.P.D.	N.P.D.	C1	C1
- door with FM > 1140x2150		✓	✓	✓	N.P.D.	N.P.D.	N.P.D.	N.P.D.
Impact resistance		✓	✓	✓	N.P.D.	N.P.D.	N.P.D.	N.P.D.
Load-bearing capacity of safety devices		✓	✓	✓	Exceeds	Exceeds	Exceeds	Exceeds
Acoustic performance		✓	✓	✓	N.P.D.	N.P.D.	N.P.D.	N.P.D.
Thermal transmittance		✓			1,90 W/m ² K	1,90 W/m ² K	1,90 W/m ² K	1,90 W/m ² K
Thermal transmittance			✓		2,00 W/m ² K	2,00 W/m ² K	2,10 W/m ² K	2,10 W/m ² K
Thermal transmittance				✓	2,00 W/m ² K	2,00 W/m ² K	2,10 W/m ² K	2,10 W/m ² K
Ability to release / open		✓	✓	✓	N.P.D.	N.P.D.	N.P.D.	N.P.D.



PROGET fire doors

Additional performances

PROGET Fire doors



PROGET
fire doors

PROGET Fire Door EI₂ 60  Certificate CE: 1404 - CPR -3737		Angular Frame	Embracing frame.	Tunnel frame	Combo with CR rebate gasket, drop-down seal and door closer for C5 version	
					CE	CE C5
Without windows 	EN 16034:2014					
	Fire resistance	✓	✓	✓	EI, 60	EI, 60
	Smoke control	✓	✓	✓	S200	S200
	Ability to release / lock	✓	✓	✓	N.P.D.	N.P.D.
	Self-closing	✓	✓	✓	C	C
	Durability of release mechanism	✓	✓	✓	N.P.D.	N.P.D.
	Durability of self-closing					
	- against degradation	✓	✓	✓	0	5
	- against corrosion	✓	✓	✓	N.P.D.	N.P.D.
	EN 14351-1:2006+A2:2016					
	Air permeability	✓	✓	✓	2	2
	Water tightness	✓	✓	✓	N.P.D.	N.P.D.
	Wind load resistance	✓	✓	✓	N.P.D.	N.P.D.
	Impact resistance	✓	✓	✓	N.P.D.	N.P.D.
	Load-bearing capacity of safety devices	✓	✓	✓	Passa	Passa
	Acoustic performance	✓	✓	✓	N.P.D.	N.P.D.
	Thermal transmittance	✓			1,40 W/m ² K	1,40 W/m ² K
	Thermal transmittance		✓		1,50 W/m ² K	1,50 W/m ² K
	Thermal transmittance			✓	1,50 W/m ² K	1,50 W/m ² K
Ability to release / open	✓	✓	✓	N.P.D.	N.P.D.	
With windows 300x400 	EN 16034:2014					
	Fire resistance	✓	✓	✓	EI, 60	EI, 60
	Smoke control	✓	✓	✓	S200	S200
	Ability to release / lock	✓	✓	✓	N.P.D.	N.P.D.
	Self-closing	✓	✓	✓	C	C
	Durability of release mechanism	✓	✓	✓	N.P.D.	N.P.D.
	Durability of self-closing					
	- against degradation	✓	✓	✓	0	5
	- against corrosion	✓	✓	✓	N.P.D.	N.P.D.
	EN 14351-1:2006+A2:2016					
	Air permeability	✓	✓	✓	2	2
	Water tightness	✓	✓	✓	N.P.D.	N.P.D.
	Wind load resistance	✓	✓	✓	N.P.D.	N.P.D.
	Impact resistance	✓	✓	✓	N.P.D.	N.P.D.
	Load-bearing capacity of safety devices	✓	✓	✓	Passa	Passa
	Acoustic performance	✓	✓	✓	N.P.D.	N.P.D.
	Thermal transmittance	✓			1,90 W/m ² K	1,90 W/m ² K
	Thermal transmittance		✓		2,10 W/m ² K	2,10 W/m ² K
	Thermal transmittance			✓	2,10 W/m ² K	2,10 W/m ² K
Ability to release / open	✓	✓	✓	N.P.D.	N.P.D.	

Additional performances

PROGET Fire doors

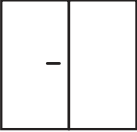
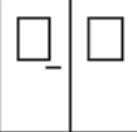
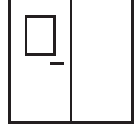

PROGET Fire Door EI ₂ 60		Angular frame	Embracing frame	Tunnel frame	Combo with CR rebate gasket and door closer for C5 version		Combo with CR rebate gasket, drop-down seal and door closer for C5 version	
					CE	CE C5	CE Sa/SF	CE Sa/SF C5
Certificate CE: 1404 - CPR -3737 								
Without windows 	EN 16034:2014							
	Fire resistance	✓	✓	✓	EI, 60	EI, 60	EI, 60	EI, 60
	Smoke control	✓	✓	✓	N.P.D.	N.P.D.	S200	S200
	Ability to release / lock	✓	✓	✓	N.P.D.	N.P.D.	N.P.D.	N.P.D.
	Self-closing	✓	✓	✓	C	C	C	C
	Durability of self-closing							
	- against degradation	✓	✓	✓	0	5	0	5
	- against corrosion	✓	✓	✓	N.P.D.	N.P.D.	N.P.D.	N.P.D.
	EN 14351-1:2006+A2:2016							
	Air permeability	✓	✓	✓	N.P.D.	N.P.D.	3	3
	Water tightness	✓	✓	✓	N.P.D.	N.P.D.	2A - 4B	2A - 4B
	Wind load resistance	✓	✓	✓				
	- door with FM ≤ 2300x2150	✓	✓	✓	N.P.D.	N.P.D.	C1	C1
	- door with FM > 2300x2150	✓	✓	✓	N.P.D.	N.P.D.	N.P.D.	N.P.D.
	Load-bearing capacity of safety devices	✓	✓	✓	Exceeds	Exceeds	Exceeds	Exceeds
	Acoustic performance	✓	✓	✓	N.P.D.	N.P.D.	N.P.D.	N.P.D.
	Thermal transmittance FM ≤ 3,6 m ²	✓			1,80 W/m ² K	1,80 W/m ² K	1,80 W/m ² K	1,80 W/m ² K
	Thermal transmittance FM > 3,6 m ²	✓			1,40 W/m ² K	1,40 W/m ² K	1,50 W/m ² K	1,50 W/m ² K
	Thermal transmittance FM ≤ 3,6 m ²		✓		1,90 W/m ² K	1,90 W/m ² K	1,90 W/m ² K	1,90 W/m ² K
	Thermal transmittance FM > 3,6 m ²		✓		1,50 W/m ² K	1,50 W/m ² K	1,60 W/m ² K	1,60 W/m ² K
Thermal transmittance FM ≤ 3,6 m ²			✓	1,90 W/m ² K	1,90 W/m ² K	1,90 W/m ² K	1,90 W/m ² K	
Thermal transmittance FM > 3,6 m ²			✓	1,50 W/m ² K	1,50 W/m ² K	1,60 W/m ² K	1,60 W/m ² K	
With windows 300x400  	EN 16034:2014							
	Fire resistance	✓	✓	✓	EI, 60	EI, 60	EI, 60	EI, 60
	Smoke control	✓	✓	✓	N.P.D.	N.P.D.	Sa	Sa
	Ability to release / lock	✓	✓	✓	N.P.D.	N.P.D.	N.P.D.	N.P.D.
	Self-closing	✓	✓	✓	C	C	C	C
	Durability of self-closing							
	- against degradation	✓	✓	✓	0	5	0	5
	- against corrosion	✓	✓	✓	N.P.D.	N.P.D.	N.P.D.	N.P.D.
	EN 14351-1:2006+A2:2016							
	Air permeability	✓	✓	✓	N.P.D.	N.P.D.	3	3
	Water tightness	✓	✓	✓	N.P.D.	N.P.D.	2A - 4B	2A - 4B
	Wind load resistance	✓	✓	✓				
	- door with FM ≤ 2300x2150	✓	✓	✓	N.P.D.	N.P.D.	C1	C1
	- door with FM > 2300x2150	✓	✓	✓	N.P.D.	N.P.D.	N.P.D.	N.P.D.
	Load-bearing capacity of safety devices	✓	✓	✓	Exceeds	Exceeds	Exceeds	Exceeds
	Acoustic performance	✓	✓	✓	N.P.D.	N.P.D.	N.P.D.	N.P.D.
	Thermal transmittance FM ≤ 3,6 m ²	✓			2,30 W/m ² K	2,30 W/m ² K	2,30 W/m ² K	2,30 W/m ² K
	Thermal transmittance FM > 3,6 m ²	✓			2,10 W/m ² K	2,10 W/m ² K	2,10 W/m ² K	2,10 W/m ² K
	Thermal transmittance FM ≤ 3,6 m ²		✓		2,40 W/m ² K	2,40 W/m ² K	2,50 W/m ² K	2,50 W/m ² K
	Thermal transmittance FM > 3,6 m ²		✓		2,20 W/m ² K	2,20 W/m ² K	2,20 W/m ² K	2,20 W/m ² K
Thermal transmittance FM ≤ 3,6 m ²			✓	2,40 W/m ² K	2,40 W/m ² K	2,50 W/m ² K	2,50 W/m ² K	
Thermal transmittance FM > 3,6 m ²			✓	2,20 W/m ² K	2,20 W/m ² K	2,20 W/m ² K	2,20 W/m ² K	

PROGET fire doors

Additional performances

PROGET Fire doors

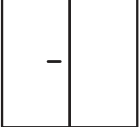
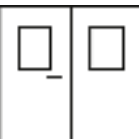
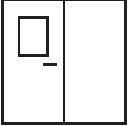

PROGET
fire doors

PROGET Fire Door EI₂ 60  Certificate CE: 1404 - CPR -3737				Angular frame	Embracing frame.	Tunnel frame	Combo with CR rebate gasket, drop-down seal and door closer for C5 version	
							CE	CE C5
Without window 	EN 16034:2014							
	Fire resistance	✓	✓	✓	EI, 60	EI, 60		
	Smoke control	✓	✓	✓	S200	S200		
	Ability to release / lock	✓	✓	✓	N.P.D.	N.P.D.		
	Self-closing	✓	✓	✓	C	C		
	Durability of self-closing				N.P.D.	N.P.D.		
	- against degradation	✓	✓	✓	0	5		
	- against corrosion	✓	✓	✓	N.P.D.	N.P.D.		
	EN 14351-1:2006+A2:2016							
	Air permeability	✓	✓	✓	3	3		
	Water tightness	✓	✓	✓	N.P.D.	N.P.D.		
	Wind load resistance	✓	✓	✓	N.P.D.	N.P.D.		
	Load-bearing capacity of safety devices	✓	✓	✓	Exceeds	Exceeds		
	Acoustic performance	✓	✓	✓	N.P.D.	N.P.D.		
	Thermal transmittance FM ≤ 3,6 m ²	✓			1,80 W/m ² K	1,80 W/m ² K		
	Thermal transmittance FM > 3,6 m ²	✓			1,50 W/m ² K	1,50 W/m ² K		
	Thermal transmittance FM ≤ 3,6 m ²		✓		1,90 W/m ² K	1,90 W/m ² K		
	Thermal transmittance FM > 3,6 m ²		✓		1,60 W/m ² K	1,60 W/m ² K		
	Thermal transmittance FM ≤ 3,6 m ²			✓	1,90 W/m ² K	1,90 W/m ² K		
	Thermal transmittance FM > 3,6 m ²			✓	1,60 W/m ² K	1,60 W/m ² K		
With window 300x400  	EN 16034:2014							
	Fire resistance	✓	✓	✓	EI, 60	EI, 60		
	Smoke control	✓	✓	✓	S200	S200		
	Ability to release / lock	✓	✓	✓	N.P.D.	N.P.D.		
	Self-closing	✓	✓	✓	C	C		
	Durability of self-closing							
	- against degradation	✓	✓	✓	0	5		
	- against corrosion	✓	✓	✓	N.P.D.	N.P.D.		
	EN 14351-1:2006+A2:2016							
	Air permeability	✓	✓	✓	3	3		
	Water tightness	✓	✓	✓	N.P.D.	N.P.D.		
	Wind load resistance	✓	✓	✓	N.P.D.	N.P.D.		
	Load-bearing capacity of safety devices	✓	✓	✓	Exceeds	Exceeds		
	Acoustic performance	✓	✓	✓	N.P.D.	N.P.D.		
	Thermal transmittance FM ≤ 3,6 m ²	✓			2,30 W/m ² K	2,30 W/m ² K		
	Thermal transmittance FM > 3,6 m ²	✓			2,10 W/m ² K	2,10 W/m ² K		
	Thermal transmittance FM ≤ 3,6 m ²		✓		2,50 W/m ² K	2,50 W/m ² K		
	Thermal transmittance FM > 3,6 m ²		✓		2,20 W/m ² K	2,20 W/m ² K		
	Thermal transmittance FM ≤ 3,6 m ²			✓	2,50 W/m ² K	2,50 W/m ² K		
	Thermal transmittance FM > 3,6 m ²			✓	2,20 W/m ² K	2,20 W/m ² K		

Additional performances

PROGET Fire doors



Essential requirements*	EN 16034	EN 14351
Fire resistance	YES	NO
Smoke control	YES	NO
Self - closing	YES	NO
Durability of performance	YES	NO
Thermal insulation	NO	YES
Air permeability	NO	YES
Water tightness	NO	NO
Acoustic performance	NO	NO
Wind resistance	NO	NO
Load-bearing capacity of safety devices	NO	YES
Release/unlocking capability (mandatory for doors installed on escape routes)	NO	YES
Minimum clear passage height: 2000 mm	NO	YES

WARNING

For doors exposed to weather conditions and/or direct sunlight, the customer must take appropriate precautions to prevent long-term deterioration, in particular:

- Canopies or overhangs
- Outdoor paint with UV protection
- Use of light RAL colours to avoid overheating of metal sheets

* Required under binding national provisions

Door cross sections - Measurements

PROGET Fire doors



PROGET
fire doors

One-leaved doors - Horizontal cross section

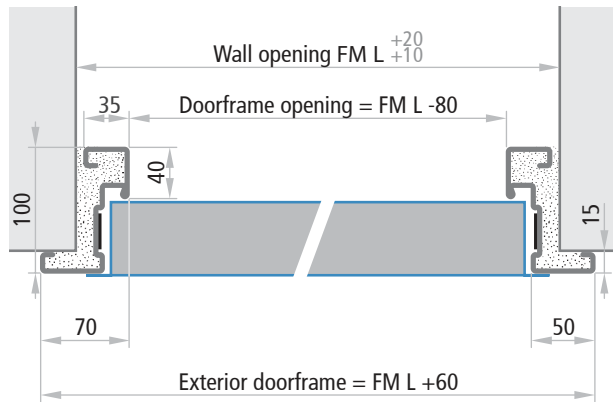

Doors without lower threshold - Vertical cross section

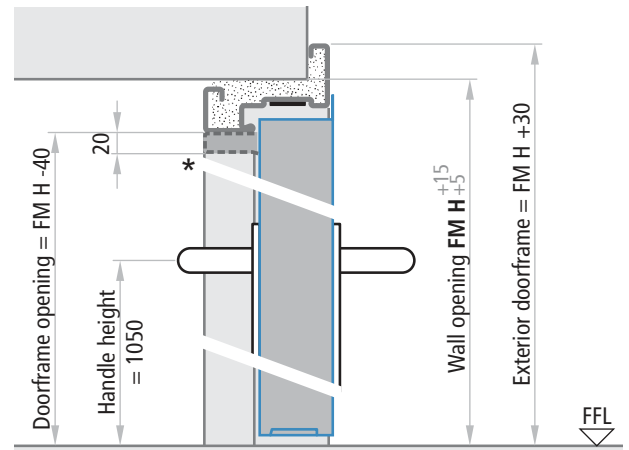

* RC/STD position in case of additional performances

Two-leaved doors - Horizontal cross section

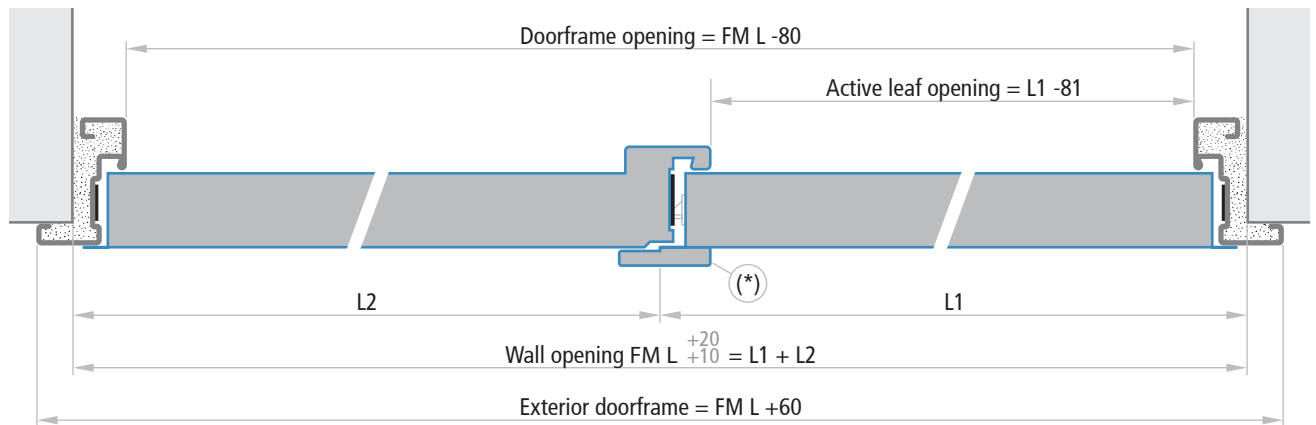

One-leaved doors with frame on 4 sides and leaf with lower rebate - Vertical cross section

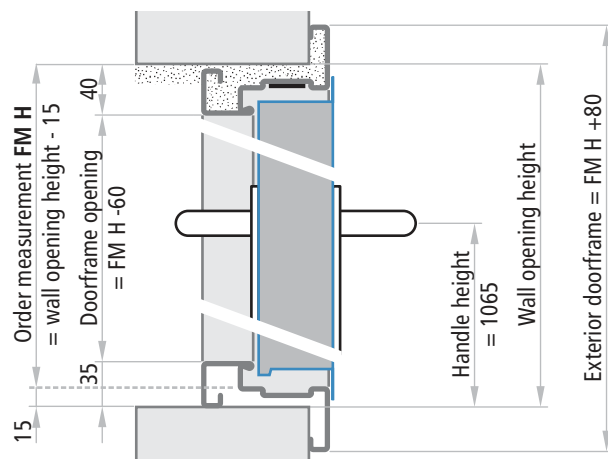

One-leaved doors with frame on 4 sides and leaf without lower rebate - Vertical cross section

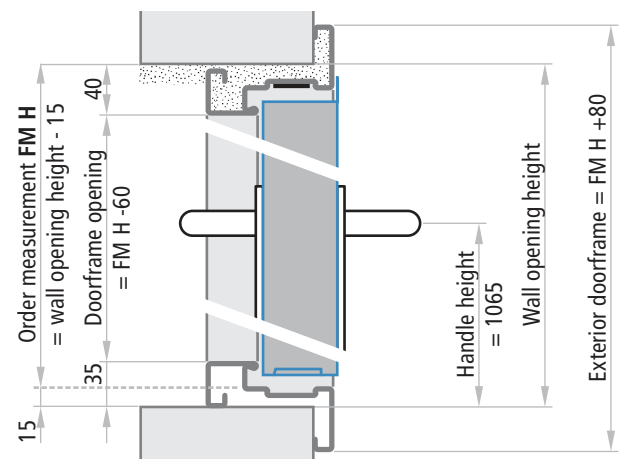

Leaves thickness

Fire doors 60 mm

NOTE

The tolerances $FM L +20$, $FM H +15$ of the indicated measurements make it easier to fill the gap between the wall and the doorframe with cement mortar.

For dry wall installation, the holes must be precise and greater tolerance ranges should not be employed.

(*) Proget EI,90 two leaved doors feature an additional isolated central rebate profile, which is applied onto the active leaf.

Standard installation method

PROGET Fire doors



PROGET
fire doors

INSTALLATION WITH ANCHORS FOR MORTAR FIXING

The standard installation method for Proget doors is to use the anchors for mortar fixing. Appropriate cuts will need to be created in the walls (section 80 x 200 mm). The anchors should be bent and blocked inside the wall. For fire sealing purposes and a perfect mechanical fit, the space between the doorframe and the masonry shall always be filled with concrete mortar.



One-leaved doors

FM L = from 500 to 1035 x FM H = from 1775 to 2200

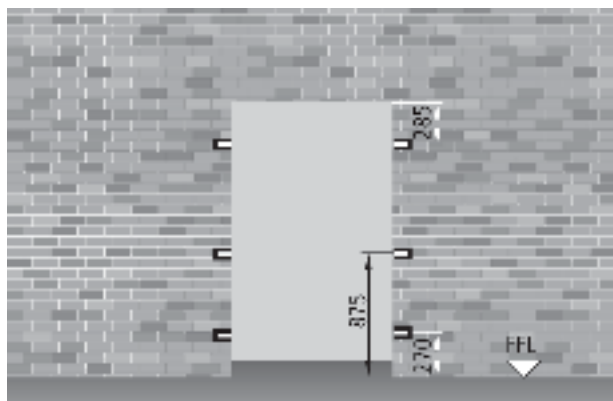

FM L greater than 1035 and/or FM H greater than 2200

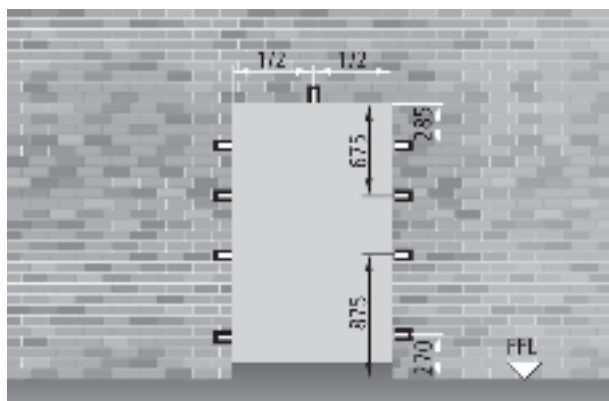

Two-leaved doors

FM L = from 850 to 2070 x FM H = from 1775 to 2200

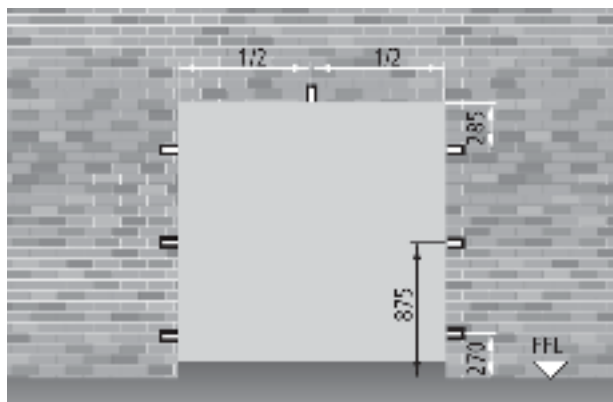

FM L greater than 2070 and/or FM H greater than 2200

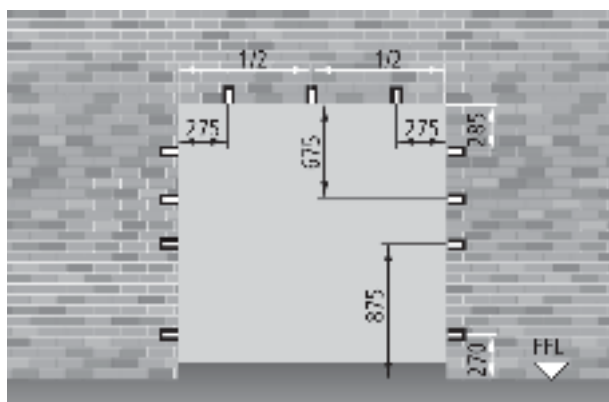

NOTE

For proper installation, the cuts for the anchors should be 80 x 200 mm in size.

Optional installation methods

PROGET Fire doors



PROGET
fire doors

DRY WALL INSTALLATION ONTO THE SUBFRAME WITH SCREWS

Installation method certified for one- or two-leaved REI 60 and REI 120 doors, in conformity with UNI 9723 standard, for screw fixing onto metal subframes in the walls.

Subframes need to be ordered separately from the door. Make sure measurements correspond to the door's FM L x FM H measurements.

For the technical characteristics of the subframe, see the specific page of the section "accessories doors".

The supplied doorframe comes factory heat-insulated with special materials and includes corner joints and a lower spacer (except for one-leaved doors with frame on four sides) to be added on site.

The subframe method allows a "dry wall" installation of the doors, making an installation onto finished masonry possible.

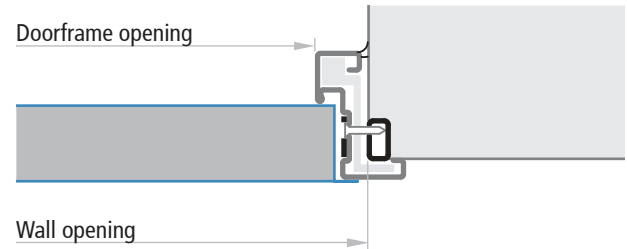

INSTALLATION FOR EXPANSION SCREWS FIXING

Installation method certified for: one- or two-leaved EI₂60, REI 60, REI 120, EI₂90 two-leaved and EI₂120 one-leaved doors, for expansion screws. Designed for installations onto blockwork, masonry or homogenous concrete wall, with density of (1200±400)kg/m³ and a thickness of (200±50)mm.

The supplied doorframe comes factory heat-insulated with special materials and includes corner joints and a lower spacer (except for one-leaved doors with frame on four sides) to be added on site.

This method allows for "dry wall" installation of the doors without requiring any additional masonry work. Installation of the door, therefore, becomes a simple mechanical operation plus the final adjustments.



EI₂60, REI 60 and REI 120 doors



EI₂90, EI₂120 doors

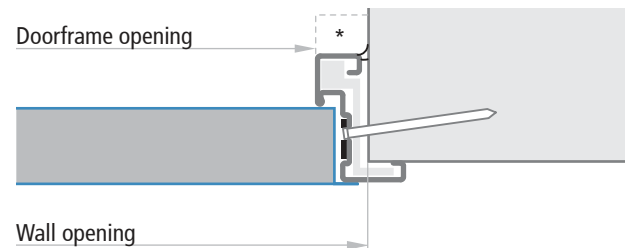

NOTE

Please specify clearly whether the door is for subframe installation or for direct wall installation with expansion screws.

* concealing with concrete mandatory for EI₂90 and EI₂120 fire-rated doors.

WALL SCREWS

For direct wall installations or installation onto subframes, special expansion screws should be used without plugs. Please see the "door accessories" pages for more details.



Optional installation methods

PROGET Fire doors



PROGET fire doors

BLOCK FRAME FOR IN THE REVEAL APPLICATION

Installation method certified for one- and two-leaved EI₂60, one-leaved EI₂120 or two-leaved EI₂90 doors. The supplied frame comes factory heat-insulated with special materials and includes corner joints and pre-drilled screw holes on the rebate. Installation for expansion screws (not supplied). This method allows for "dry wall" installation of the doors without requiring any additional masonry work. Installation of the door, therefore, becomes a simple mechanical operation plus the final adjustments.



ATTENTION

Acoustic performance values are not valid in case of block frame for in the reveal application.

DOOR CROSS SECTIONS - MEASUREMENTS

One-leaved doors

Horizontal cross section

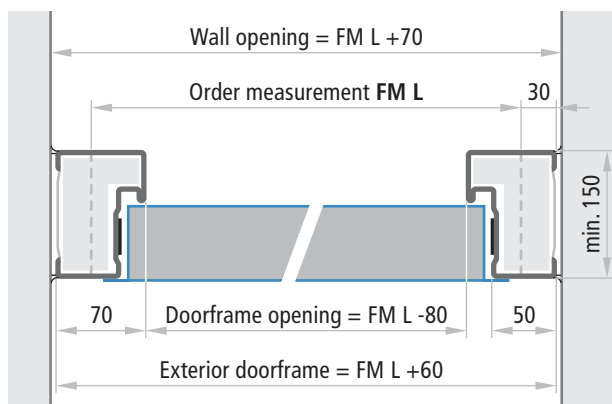

Doors without lower threshold

Vertical cross section

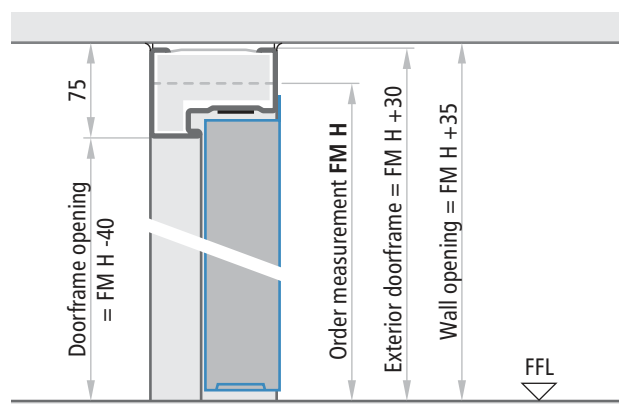

Two-leaved doors

Horizontal cross section

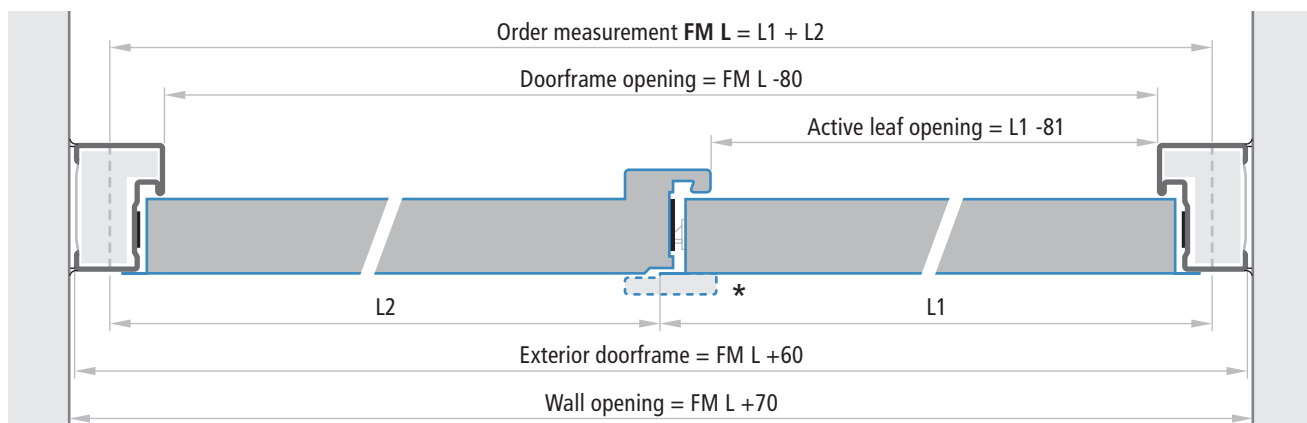

NOTE

Expansion screws recommended:

- for light wall Würth type DBL-(WUS-SK)-Z3-180-10x202
- for heavy wall Spit type L 10 - 102/152

(*) Proget EI₂90 two leaved doors feature an additional isolated central rebate profile, which is applied onto the active leaf.

Lightweight construction installation

PROGET Fire doors



PROGET
fire doors

LIGHTWEIGHT CONSTRUCTION INSTALLATION WITH EMBRACING FRAME

Installation method onto lightweight constructions certified for one- or two-leaved doors. The supplied frame comes factory heat-insulated with special materials and includes corner joints and pre-drilled screw holes with cover caps.

Door cross section and lightweight construction version: EI₂60

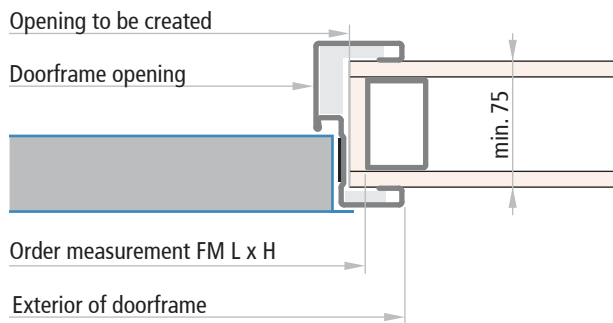

Door cross section and plasterboard version: REI 60

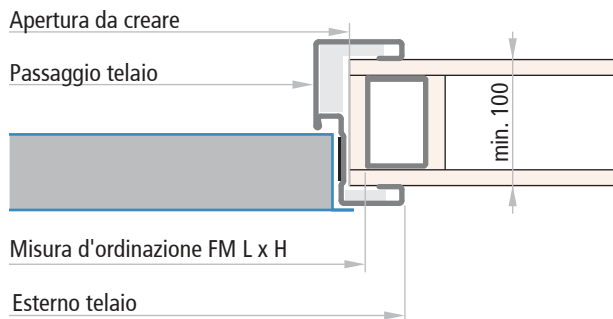

Door cross section and plasterboard version: REI 120 EI₂60 - EI₁20

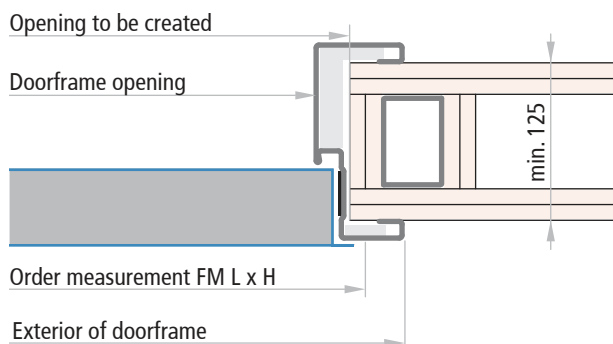

Lightweight constructions EI₂60

EI₂60 fire-rated doorsets can be installed onto every wall or partition which is of the board covered type with studs made from metal or timber with a fire resistance equal to or greater than the EI60 supporting construction.

Order measurement	required wall opening	doorframe opening	exterior of doorframe
FM L (width)	FM L - 25 mm	FM L - 80 mm	FM L + 60 mm
FM H (height)	FM H - 12 mm	FM H - 40 mm	FM H + 30 mm

NOTE

Lightweight constructions should be done following the specific door installation instructions.

Plasterboard walls REI 60

Made using galvanized steel frames with "U"-shaped 75x40mm min. guide profiles, "C"-shaped 75x47mm min. vertical profiles (doubled next to the doorframe), with a single layer of 12,5mm min. thick fire rated plasterboard used as finishing on both sides and on the profiles around the doorframe.

Order measurement	Required wall opening	Doorframe opening	Exterior of doorframe
FM L (width)	FM L - 25 mm	FM L - 80 mm	FM L + 60 mm
FM H (height)	FM H - 12 mm	FM H - 40 mm	FM H + 30 mm

Plasterboard walls EI₂90, EI₂120 and REI 120

Made using galvanized steel framing with "U"-shaped 75x40mm min. guide profiles, "C"-shaped 75x47mm min. vertical profiles (doubled next to the doorframe), with a double layer of 12,5mm min. thick fire rated plasterboard used as finishing on both sides and on the profiles around the doorframe.

Order measurement	required wall opening	doorframe opening	exterior of doorframe
FM L (width)	FM L - 25 mm	FM L - 80 mm	FM L + 60 mm
FM H (height)	FM H - 12 mm	FM H - 40 mm	FM H + 30 mm



Order measurements

PROGET Fire doors



ORDER MEASUREMENTS

Wall opening

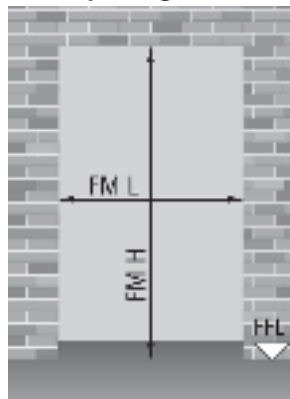

Doorframe opening



$$PTL = FM L - 80$$

$$PTH = FM H - 40$$

Lightweight constructions wall opening

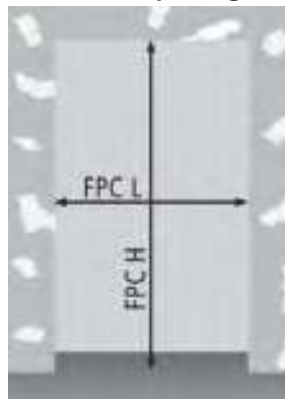

$$FPC L = FM L - 25$$

$$FPC H = FM H - 12$$

Block frame opening

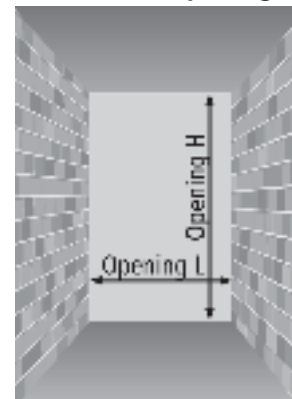

$$\text{Opening L} = FM L + 70$$

$$\text{Opening H} = FM H + 35$$

PROGET
fire doors

NOTE

The wall openings to be created for the embracing frame or the block frame for in the reveal application, do not correspond to the order measurement and therefore should follow the above specifications.

One-leaved doors

FM L x FM H standard dimensions	PT L x PT H (doorframe opening) frame on 3 sides		fire-rating class
	frame on 3 sides	frame on 4 sides	
800 x 2000 / 2050 / 2100 / 2150 / 2200	720 x 1960 / 2010 / 2060 / 2110 / 2160	720 x 1940 / 1990 / 2040 / 2090 / 2140	EI ₂ 60, EI ₂ 120, REI 60, REI 120
900 x 2000 / 2050 / 2100 / 2150 / 2200	820 x 1960 / 2010 / 2060 / 2110 / 2160	820 x 1940 / 1990 / 2040 / 2090 / 2140	EI ₂ 60, EI ₂ 120, REI 60, REI 120
1000 x 2000 / 2050 / 2100 / 2150 / 2200	920 x 1960 / 2010 / 2060 / 2110 / 2160	920 x 1940 / 1990 / 2040 / 2090 / 2140	EI ₂ 60, EI ₂ 120, REI 60, REI 120
1100 x 2050 / 2100 / 2150 / 2200	1020 x 2010 / 2060 / 2110 / 2160	1020 x 1990 / 2040 / 2090 / 2140	EI ₂ 60, EI ₂ 120, REI 60, REI 120
1200 x 2050 / 2100 / 2150 / 2200	1120 x 2010 / 2060 / 2110 / 2160	1120 x 1990 / 2040 / 2090 / 2140	EI ₂ 60, EI ₂ 120, REI 60, REI 120
1300 x 2000 / 2050 / 2100 / 2150 / 2200	1220 x 1960 / 2010 / 2060 / 2110 / 2160	1220 x 1940 / 1990 / 2040 / 2090 / 2140	EI ₂ 60, EI ₂ 120, REI 60, REI 120
1340 x 2050 / 2100 / 2150 / 2200	1260 x 2010 / 2060 / 2110 / 2160	1260 x 1990 / 2040 / 2090 / 2140	EI ₂ 60, EI ₂ 120, REI 60, REI 120
non-standard dimensions			
from 670 to 1340 x from 1950 to 2600	from 590 to 1260 x from 1910 to 2560	from 590 to 1260 x from 1890 to 2540	EI ₂ 60
from 710 to 1340 x from 1900 to 2640	from 630 to 1260 x from 1860 to 2600	from 630 to 1260 x from 1840 to 2580	EI ₂ 120
from 546 to 1340 x from 1775 to 2670	from 466 to 1260 x from 1735 to 2630	from 466 to 1260 x from 1715 to 2610	REI 60, REI 120 anchor fixing
from 546 to 1170 x from 1775 to 2275	from 520 to 1090 x from 1735 to 2235	from 520 to 1090 x from 1715 to 2215	REI 60, REI 120 embracing frame
from 1004 to 1340 x from 2050 to 2500	from 924 to 1260 x from 2010 to 2460	from 924 to 1260 x from 1990 to 2440	REI 60, REI 120 embracing frame
from 546 to 1170 x from 1775 to 2275	from 520 to 1090 x from 1735 to 2235	from 520 to 1090 x from 1715 to 2215	REI 60, REI 120 subframe or expansion screw
from 1004 to 1340 x from 2050 to 2500	from 924 to 1260 x from 2010 to 2460	from 924 to 1260 x from 1990 to 2440	REI 60, REI 120 subframe or expansion screw

Order measurements - Handle height

PROGET Fire doors

NINZ
FIREDOORS

PROGET
fire doors

Two-leaved doors FM L x FM H				PT L x PT H	fire-rating
standard dimensions				doorframe opening	class
1150	(800 + 350)	x	2000 / 2050 / 2100 / 2150 / 2200	1070 x 1960 / 2010 / 2060 / 2110 / 2160	EI,60, REI 60, REI 120
1200	(800 + 400)	x	2000 / 2050 / 2100 / 2150 / 2200	1120 x 1960 / 2010 / 2060 / 2110 / 2160	EI,60, REI 60, REI 120
1250	(800 + 450)	x	2000 / 2050 / 2100 / 2150 / 2200	1170 x 1960 / 2010 / 2060 / 2110 / 2160	EI,60, REI 60, REI 120
1250	(900 + 350)	x	2000 / 2050 / 2100 / 2150 / 2200	1170 x 1960 / 2010 / 2060 / 2110 / 2160	EI,60, REI 60, REI 120
1300	(900 + 400)	x	2000 / 2050 / 2100 / 2150 / 2200	1220 x 1960 / 2010 / 2060 / 2110 / 2160	EI,60, REI 60, REI 120
1350	(900 + 450)	x	2000 / 2050 / 2100 / 2150 / 2200	1270 x 1960 / 2010 / 2060 / 2110 / 2160	EI,60, REI 60, REI 120
1350	(1000 + 350)	x	2000 / 2050 / 2100 / 2150 / 2200	1270 x 1960 / 2010 / 2060 / 2110 / 2160	EI,60, REI 60, REI 120
1400	(1000 + 400)	x	2000 / 2050 / 2100 / 2150 / 2200	1320 x 1960 / 2010 / 2060 / 2110 / 2160	EI,60, REI 60, REI 120
1450	(1000 + 450)	x	2000 / 2050 / 2100 / 2150 / 2200	1370 x 1960 / 2010 / 2060 / 2110 / 2160	EI,60, REI 60, REI 120
1600	(800 + 800)	x	2000 / 2050 / 2100 / 2150 / 2200	1520 x 1960 / 2010 / 2060 / 2110 / 2160	EI,60, EI,90, REI 60, REI 120
1700	(900 + 800)	x	2000 / 2050 / 2100 / 2150 / 2200	1620 x 1960 / 2010 / 2060 / 2110 / 2160	EI,60, EI,90, REI 60, REI 120
1800	(900 + 900)	x	2000 / 2050 / 2100 / 2150 / 2200	1720 x 1960 / 2010 / 2060 / 2110 / 2160	EI,60, EI,90, REI 60, REI 120
1800	(1000 + 800)	x	2000 / 2050 / 2100 / 2150 / 2200	1720 x 1960 / 2010 / 2060 / 2110 / 2160	EI,60, EI,90, REI 60, REI 120
1900	(1000 + 900)	x	2000 / 2050 / 2100 / 2150 / 2200	1820 x 1960 / 2010 / 2060 / 2110 / 2160	EI,60, EI,90, REI 60, REI 120
2000	(1000 + 1000)	x	2000 / 2050 / 2100 / 2150 / 2200	1920 x 1960 / 2010 / 2060 / 2110 / 2160	EI,60, EI,90, REI 60, REI 120

non-standard dimensions

from 890 (540 + 350) to 2540 (1270 + 1270)	x	from 1775 to 2600	from 810 to 2460	x	from 1735 to 2560	EI,60
from 1175 (600 + 575) to 2540 (1270 + 1270)	x	from 1775 to 2300	from 1095 to 2460	x	from 1735 to 2260	EI,90
from 1175 (600 + 575) to 2500 (1250 + 1250)	x	from 2301 to 2500	from 1095 to 2420	x	from 2261 to 2460	EI,90
from 1175 (600 + 575) to 2380 (1200 + 1180)	x	from 2501 to 2630	from 1095 to 2300	x	from 2461 to 2590	EI,90
from 890 (540 + 350) to 2540 (1270 + 1270)	x	from 1775 to 2670	from 810 to 2460	x	from 1735 to 2630	REI 60, REI 120 anchor fixing
from 890 (540 + 350) to 2298 (1164 + 1134)	x	from 1775 to 2275	from 810 to 2218	x	from 1735 to 2235	REI 60, REI 120 embracing frame
from 1962 (996 + 966) to 2540 (1270 + 1270)	x	from 2050 to 2500	from 1882 to 2460	x	from 2010 to 2460	REI 60, REI 120 embracing frame
from 890 (540 + 350) to 2298 (1164 + 1134)	x	from 1775 to 2275	from 810 to 2218	x	from 1735 to 2235	REI 60, REI 120 subframe or expansion screw
from 1962 (996 + 966) to 2540 (1270 + 1270)	x	from 2050 to 2500	from 1882 to 2460	x	from 2010 to 2460	REI 60, REI 120 subframe or expansion screw

NOTE

The following doors are equipped with a CP1 door closer:

EI ₂ 90	2 leaves:	from 2271 to 2540 x from 2151 to 2300
		from 1801 to 2500 x from 2301 to 2500
		from 1801 to 2380 x from 2501 to 2630
EI ₂ 120	1 leaf:	from 1126 to 1340 x from 2301 to 2500
		from 901 to 1340 x from 2501 to 2640
REI 120	1 leaf:	from 1126 to 1340 x from 2301 to 2500
		from 901 to 1340 x from 2501 to 2670
	2 leaves:	from 1126 to 1270 x from 2151 to 2300
		from 901 to 1270 x from 2301 to 2670

HANDLE HEIGHT

One-leaved door

h = 1050 (FM H ≥ 1750)

Different heights available upon request only



Two-leaved door

h = 1050 (FM H ≥ 1750)

Different heights available upon request only



Opening measurements - Overall dimensions

PROGET fire doors



PROGET fire doors

OPENING MEASUREMENTS AND OVERALL DIMENSIONS WITH 90 DEGREE OPENING

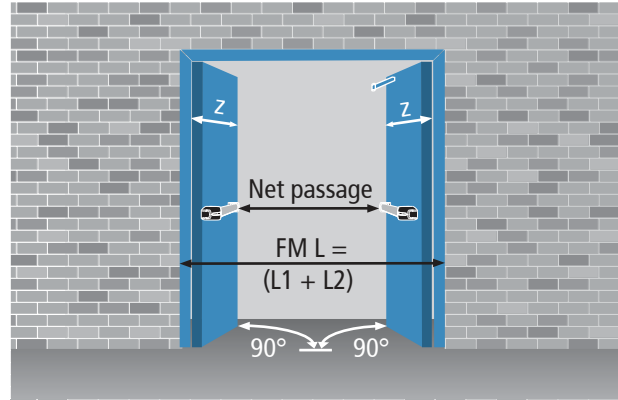
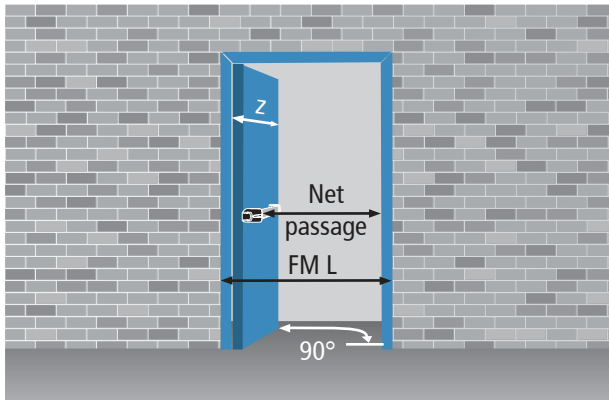

Net passage calculation

panic bar type	protrusion	one-leaved door	two-leaved door	one-leaved door with block frame	two-leaved door with block frame
EXUS	125	FML - 245	FML - 410	Opening - 315	Opening - 480
TWIST	100	FML - 220	FML - 360	Opening - 290	Opening - 430
SLASH	75	FML - 195	FML - 310	Opening - 265	Opening - 380
FAST TOUCH	75	FML - 195	FML - 310	Opening - 265	Opening - 380
without panic bar	-	FML - 120	FML - 160	Opening - 190	Opening - 230
z = leaf protrusion relative to the wall		FML + 27		EI ₂ 60, REI 60, REI 120 = L ₁ + 35, L ₂ + 75; EI ₁ 90 = L ₁ + 67, L ₂ + 75	

OVERALL DIMENSIONS WITH 180 DEGREE OPENING

One-leaved door

$x = FML - 7$

Two-leaved door

$EI_{2,60}, REI 60, REI 120: x = L_1 + 1; EI_{1,90}: x = L_1 + 33; y = L_2 + 42$
 $b = \max. 130$ (only in the presence of a panic bar or M14 handle)

